

MODEL 137 VIGILANT™

AIRCRAFT HYGROMETER SYSTEM

OPERATORS MANUAL



WARRANTY STATEMENT

All equipment manufactured by Edgetech Instruments Inc. is warranted against defective components and workmanship for repair at their plant in Massachusetts, free of charge, for a period of twelve months. Malfunction due to improper use is not covered in this warranty and Edgetech Instruments Inc. disclaims any liability for consequential damage resulting from defects in the performance of the equipment. No product is warranted as being fit for a particular purpose and there is no warranty of merchantability. This warranty applies only if (i) the items are used solely under the operating conditions and in the manner recommended in the instruction manual, specifications, or other literature; (ii) the items have not been misused or abused in any manner or repairs attempted thereon; (iii) written notice of the failure within the warranty period is forwarded to Edgetech Instruments Inc. and the directions received for properly identifying items returned under warranty are followed; and (iv) the return notice authorizes Edgetech Instruments Inc. to examine and disassemble returned products to the extent Edgetech Instruments Inc. deems necessary to ascertain the cause for failure. The warranties expressed herein are exclusive. There are no other warranties, either expressed or implied, beyond those set forth herein, and Edgetech Instruments Inc. does not assume any other obligation or liability in connection with the sale or use of said products.

Equipment not manufactured by Edgetech Instruments Inc. is supported only to the extent of the original manufacturer's warranties

Edgetech Instruments's Commitment to Quality

To Our Customers:

Thank you for purchasing one of our products. At Edgetech Instruments Inc., it is our policy to provide cost-effective products and support services that meet or exceed your requirements, to deliver them on time, and to continuously look for ways to improve both. We all take great pride in the products we manufacture.

We want you to be entirely satisfied with your instrument. The information contained in this manual will get you started. It tells you what you need to get your equipment up and running, and introduces its many features.

We always enjoy hearing from the people who use our products. Your experience with our products is an invaluable source of information that we can use to continuously improve what we manufacture. We encourage you to contact or visit us to discuss any issues whatsoever that relate to our products or your application.

The Employees of Edgetech Instruments Inc.

Table of Contents

SECTION

INTRODUCTION	1
1.1	GENERAL DESCRIPTION
1.2	SYSTEM OVERVIEW
1.3	SENSORS
1.4	CONTROL UNIT
INSTALLATION	2
2.1	UNPACKING
2.2	CONTROL UNIT INSTALLATION
2.2.1	Unit Placement
2.2.2	Wiring Connections
2.3	MOUNTING OPTIONS
2.3.1	Control Unit Mounting
2.3.2	Sensor Mounting
2.4	SENSOR SETUP
INSTRUMENT OPERATION	3
3.1	KEYPAD OPERATION
3.2	SETUP MENUS
3.2.1	System Setup Menu
3.2.2	Display Setup Menu
3.2.3	Serial Setup Menu
3.2.4	ABC Setup Menu
3.2.5	Analog Output Setup Menu
3.3	SERIAL PORT SETUP
3.3.1	External Device Connection
3.3.2	PC or Terminal Setup
3.4	RS-232 COMMANDS AND PARAMETER SETTING
3.4.1	General
3.4.2	Help Menu
	Table 3-3. Help menu
3.4.3	Start an ABC Cycle
3.4.4	ABC Enable
3.4.5	ABC Start Time
3.4.6	ABC Interval
3.4.7	ABC Analog Hold
3.4.8	Number of Data Samples to Average
3.4.9	Analog Output (Low) (High) (param)
3.4.10	Date
3.4.11	Output Interval

- 3.4.12 Poll for Output
- 3.4.13 Manual Heat
- 3.4.14 Manual Cool
- 3.4.15 Time
- 3.4.16 Units (F,C)
- 3.4.17 Status Report

THEORY OF OPERATION4

- 4.1 SYSTEM OVERVIEW
 - 4.1.1 Main Control Loop
 - 4.1.2 Data Acquisition
 - 4.1.3 Mirror Temperature Control Loop
 - 4.1.4 Automatic Balance Cycle (ABC)

MAINTENANCE AND CALIBRATION.....5

- 5.1 ROUTINE MAINTENANCE
- 5.2 MIRROR CLEANING SCHEDULE
- 5.3 MIRROR CLEANING
- 5.4 CALIBRATION OF PRT
- 5.5 PRT AMPLIFIER CHECK
- 5.6 OPERATING ADJUSTMENTS
 - 5.6.1 Sensor Balance
 - 5.6.2 Servo Gain
 - 5.6.3 RZERO Adjust
 - 5.6.4 Display Contrast

SPECIFICATIONS.....6**INSTRUMENT FACTORY OPTIONS (Special Order) 7**

- 7.1 PARAMETERS
- 7.2 ANALOG OUTPUTS
- 7.3 ISOLATED ANALOG OUTPUTS
- 7.4 ALARM RELAYS

APPENDICES

- A. Hygrometer Control Unit, Installation Requirements
- B. Instrument Mounting Dimensions
- C. Sensor Unit, Configuration Control Drawing
- D. Basic Humidity Definitions

List of Illustrations

FIGURE

- 1-1 Front Panel, EdgeTech 137 Vigilant Aircraft Hygrometer
- 1-2 Rear Panel, EdgeTech 137 Vigilant Aircraft Hygrometer
- 1-3 Vigilant 137 System

- 3-1 Main Operating Display
- 3-2 SETUP Display
- 3-3 SYSTEM SETUP Display
- 3-4 DISPLAY SETUP Display
- 3-5 SERIAL SETUP Display
- 3-6 ABC SETUP Display
- 3-7 ANALOG OUTPUT SETUP Display

- 5-1 Mirror Access
- 5-2 Cleaning the mirror
- 5-3 Enclosure Cover and Bezel Removal
- 5-4 View of Interior with Cover Removed
- 5-5 Main PC Board

List of Tables

- 2-1 Analog Output Wiring

- 3-1 RS-232 HELP Menu



Figure 1-1 Instrument Front Panel



Figure 1-2 Instrument Rear Panel

1.0 INTRODUCTION

1.1 GENERAL DESCRIPTION

The V1, Vigilant Dew Point Hygrometer (Figures 1-1, 1-2 and 1-3) is a microprocessor based, programmable humidity measurement instrument with many microprocessor controlled features built-in.

Using the Optical Chilled Mirror (OCM) primary measurement technique, Vigilant was developed for continuous unattended operation as well as for research applications. Two sensors are available, with a depression of either 45°C (A1) or 65°C (A3) from an ambient temperature of 25°C.

1.2 SYSTEM OVERVIEW

The 137 Vigilant System consists of a Control Unit, an A1 or A3 chilled mirror Dew Point Sensor, and the interconnecting cable. Not shown in Figure 1-3 is the external sampling probe, also included.



Figure 1-3 Vigilant System

The basic Control Unit has a menu-driven

LCD graphics display, parameter averaging, Automatic Balance Cycle (ABC), one set of analog outputs, and an RS232C serial port.

The Automatic Balance Cycle (ABC) can be set to calibrate the sensor optics at preset times and intervals or can be initiated manually at any time.

The analog output is available on a rear panel connector as 0 to 5 VDC and 4 to 20 mA, and can be set to follow the measured Dew Point with individually adjustable high and low limits. The outputs can be set to **Track** the Dew Point temperature during the ABC cycle or **Hold** the last value prior to the ABC cycle. The half-duplex configured RS232C serial port can be used to setup functions, control the operation, and output data to a data-recording device.

1.3 SENSORS

The sensors have a chromium-plated mirror to provide superior corrosion and abrasion resistance. The sensor is normally mounted on an outside surface of the aircraft, and a 15 foot cable is provided to connect it to the rear panel of the instrument. Either a left-hand mount or a right-hand mount sensor configuration must be specified when ordering.

1.4 CONTROL UNIT

The Vigilant Control Unit operates entirely under microprocessor control. State-of-the-art software provides the opportunity to include a flexible, informational, and user friendly interface. The setup and operation of the control unit can be programmed via the front panel keypad or the RS-232 serial port.

— **LCD Graphics Display:** displays time, date, operational status, sensor mirror

condition, and alerts the user to fault conditions. The display is backlit for easy readability.

— **Keypad:** Five, membrane type ‘soft keys’ allow the user to enter setup and instrument control information. A hierarchical menu structure guides the user through the setup procedure. The Setup Parameters include time plus date, ABC start and interval, analog output parameter and scale, serial port, and digital averaging.

— **SERVOLOCK™:** The SERVOLOCK feature continuously displays the servo control loop status. This is especially useful when the sample dew point is varying widely or quickly. When SERVOLOCK is displayed, the system is locked on to and tracking the dew point.

— **ABC Cycle:** The Automatic Balance Cycle checks for proper operation of the system and re-balances the sensor to compensate for changes in reflectivity of the mirror due to aging, optics drift, or minor contamination due to impurities in the sample air. The on-board real time clock permits the user to program the ABC cycle to start at any specified time of day and repeat at regular-programmed intervals. The user can therefore program the ABC cycle to occur at off-hours such as late at night or early morning when the re-balance will cause the least interruption of the measurement. The cycle can also be initiated manually at any time by a push-button on the front panel or via the serial port.

The analog outputs can be programmed to TRACK or HOLD the parameters

during an ABC cycle and the alarms are automatically disabled.

— **Serial Port:** The RS232C serial port can be used to remotely program setup parameters, initiate an ABC cycle, or output data to a local or remote terminal, printer, or computer. The data output function outputs the date, time, system status to any RS232C equipped serial device. The data can be sent on command from the external device or automatically at programmed intervals. HELP and STATUS menus can also be displayed to guide the user.

— **Operating Controls:** During normal operation, the five-keypad keys allow the user to change units(C to F), start an ABC cycle, initiate maximum cool/heat, or enter the setup menu.

— **Analog Outputs:** Two simultaneous analog outputs, 0-5 VDC and 4-20 mA, are available at a rear connector. These outputs track the dew point, and are independently scaled via the setup menu.

2.0 INSTALLATION

2.1 UNPACKING

Remove the Vigilant Dew Point Hygrometer from its shipping carton and remove any shipping ties, clamps, and packing material. Save the Certificate of Calibration shipped with this manual. The Model A1 or A3 sensor (user specified) is also included in the shipment, along with a 15 foot interconnecting cable.

2.2 CONTROL UNIT INSTALLATION

2.2.1 UNIT PLACEMENT

Install the Vigilant instrument in locations where the ambient temperature will not exceed the specified ambient temperature range.

Locate the dew point sensor on an outside surface of the aircraft. A left or right side mount has been supplied. See the Configuration Control drawing in the Appendix to determine proper air flow direction and other mounting information. Note that the sensor temperature should be at least 10°C above the dew point temperature of the air being measured. This prevents unwanted condensation on the inside of the sensor body. In addition, it supports proper operation of the heat pump control circuit.

2.2.2 WIRING CONNECTIONS

Connect the Vigilant control unit to a grounded, instrument quality power source of between 90 to 250 VAC, 50-400 Hz.

CAUTION

Removing the Vigilant control unit cover exposes the user to line operating voltages when the unit is connected to line power. Only experienced persons should attempt to make adjustments or tests with the cover removed. If the instrument is plugged in when performing any circuit adjustments or tests, take extreme care not to come in contact with the high voltage present around the switching power supply, the AC line filter, or the rear panel power switch.

The Analog Output connector on the rear panel is supplied with a mating connector, which is pre-wired for user convenience. The short wires supplied may be spliced to longer wires, or may be unsoldered and replaced with longer wires. Color codes should be maintained. Table 2-1 below shows the standard pin connections.

Pin	Color	Item
A	Red	+5VDC
B	Black	Com.
C	White	4 to 20 mA

Table 2-1 Analog Output Wiring

2.3 MOUNTING OPTIONS

2.3.1 CONTROL UNIT MOUNTING

When selecting the location for the Control Unit, you must take into account the 15 feet of sensor interconnecting cable. The Vigilant Control Unit is furnished with a shock-mounted

base. The base should be firmly affixed to the aircraft structure or to an instrument mounting rack. Additional space should be allowed at the back of the unit to accommodate interconnecting cables. Sufficient space (at least three inches) around all sides of the Control Unit should be allowed for normal flight motion. The Control Unit may be removed from its mount by simply rotating the single thumb screw on the front panel of the mount.

3.0 INSTRUMENT OPERATION

2.3.2 SENSOR MOUNTING

The dew point sensor is normally mounted to the wing of the aircraft, but other locations may be acceptable, depending on the type of aircraft. Again, keep the 15 foot cable length in mind. Figure C in the Appendix contains probe mounting instructions. It is imperative that air flow direction be observed for proper operation.

Figure 3-1 Main Operating Display

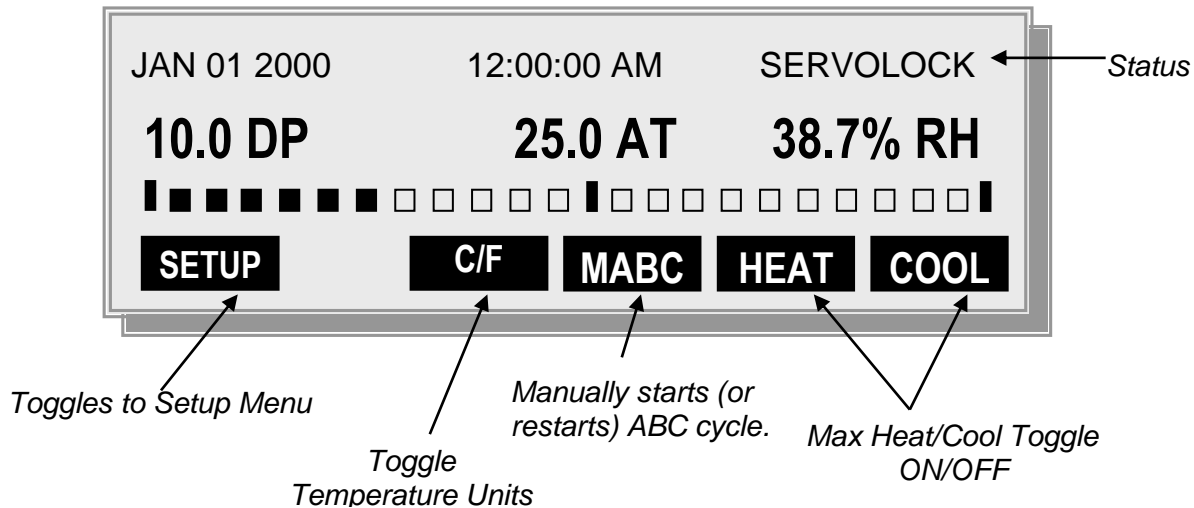

3.1 KEYPAD OPERATION

The 137 Vigilant front panel has five soft keys that support user set up and operation. The label for each key, and its function, changes as the user moves through the setup menu and operates Vigilant. The information below each figure gives a description of each soft key function.

<u>Key</u>	<u>Function</u>
------------	-----------------

<i>SETUP</i>	Toggles to the SETUP display.
--------------	-------------------------------

<i>C/F</i>	Toggles the displayed parameters, internal parameters and RS-232 output between degrees Fahrenheit and Centigrade. Thus it is important to choose operation in C or F <u>before</u> any other set-up activity.
------------	--

Output values are converted from Fahrenheit to Centigrade when the C/F soft key is pressed. The analog output level does not change when C/F is toggled, because ranges are converted.

MABC Starts the Manual ABC cycle. If the Vigilant is already in an ABC cycle, this key cancels the ABC cycle.

HEAT Turns on/off MAX HEAT. Once this key is pressed, the sensor is kept in MAX HEAT until the MAX HEAT soft key is pressed again. In MAX HEAT ServoLock is bypassed and the mirror is heated. The upper right section of the LCD flashes MAN MAX HEAT, and the RS-232 output indicates MAX HEAT. During an ABC cycle, MAX

HEAT (MAX COOL) does not function.

NOTE:

Turning on MAX HEAT turns off MAX COOL and vice versa. Both cannot be activated simultaneously.

COOL Turns on/off MAX COOL. The sensor is kept in MAX COOL until the MAX COOL soft key is pressed again. The upper right portion of the LCD flashes MAN MAX COOL.

3.2 SETUP MENUS

Figure 3-2 SETUP Display

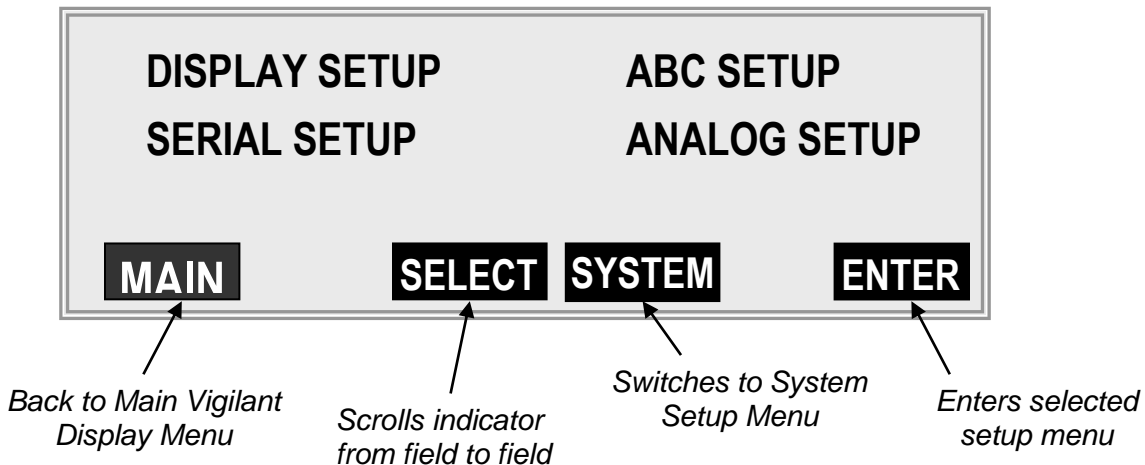

The SETUP display facilitates access to DISPLAY setup, SERIAL setup, ABC setup, and ANALOG setup.

Key Function

MAIN Returns to the MAIN operating display.

SELECT Advances the function selection indicator from field to field.

SYSTEM Switches to the SYSTEM SETUP display.

ENTER Toggles the display to the function highlighted by the selection indicator.

3.2.1 SYSTEM SETUP MENU

Figure 3-3 System Setup Display

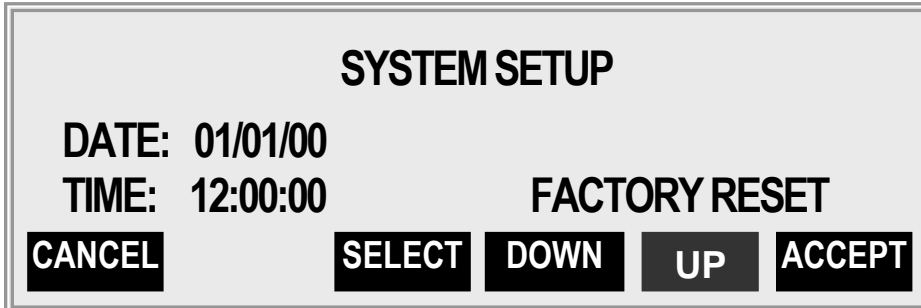

The SYSTEM SETUP display is used to set the date and time of day.

<u>Key</u>	<u>Function</u>
<i>CANCEL</i>	Returns VIGILANT to the MAIN operating display with no changes.
<i>SELECT</i>	Advances the function selection indicator among the items that the user can adjust. The order of choice is: month, date, year, hour, minutes, seconds, pressure, reset, then back to month.
<i>DOWN</i>	Reduces the value for the selected field. For example, if the field selected is month and the

value shown is 12 (December), when DOWN is pressed, the month becomes 11 (November). Pressing DOWN again makes the value 10 (October).

<i>UP</i>	Increases the value in the selected field. For example, if the field selected is month and the value shown is 12, when UP is pressed, the month becomes 1 (January). Pressing UP again makes the value 2 (February).
<i>ACCEPT</i>	Pressed when the user is satisfied with all displayed values. The values are stored in non-volatile memory. Vigilant returns to the SETUP display.

3.2.2 DISPLAY SETUP MENU

Figure 3-4 Display Setup Display

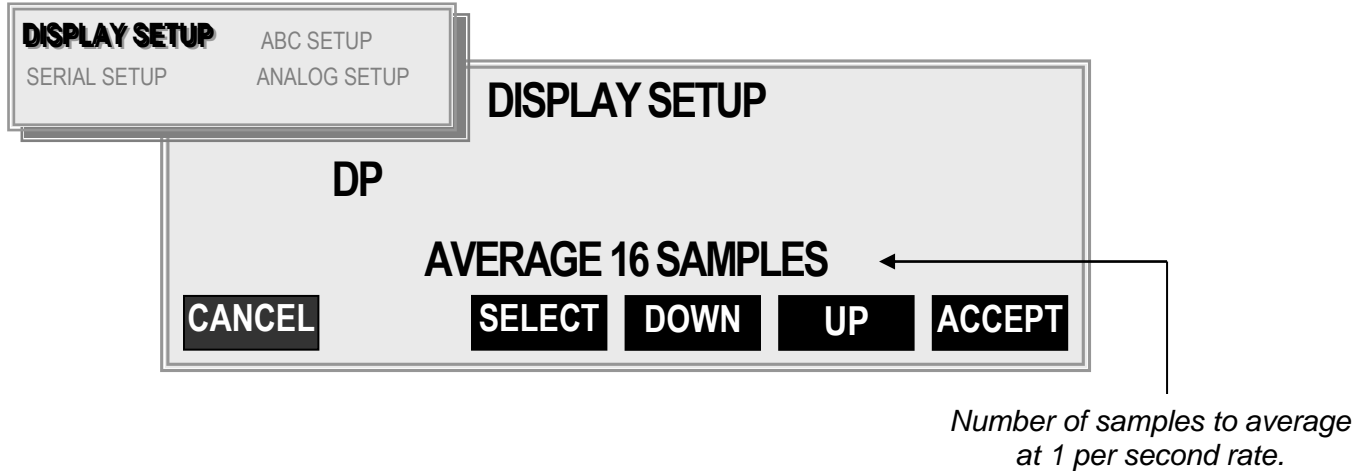

The *DISPLAY SETUP* display is used to select parameters to appear on the MAIN display, and to select sample averaging. With Average set to 1, as each individual determination is made, it is shown on the display. With Average set to 2, the 2 most recent determinations are added together and divided by 2, then displayed. With average set to 16, the 16 most recent determinations are averaged together for display.

<u>Key</u>	<u>Function</u>
------------	-----------------

<i>CANCEL</i>	Returns to the SETUP display.
<i>SELECT</i>	Advances the function selection indicator from field to field. The choices are: first, second and third displayed parameter, then number of determinations to be averaged.
<i>DOWN</i>	Cycles through the choices for the selected field. For example, if AVERAGE is currently 10, pressing DOWN results in 9.

If AVERAGE is set to 1, the fastest dynamic response is achieved. However, if there is some noise or artifact, it will be displayed. If AVERAGE is set to 16, since one determination is made per second, the most recent 16 seconds of data is averaged to provide each displayed value. If there is some random noise or small but irrelevant changes in dew point, setting AVG to 16 will smooth out unwanted or irrelevant changes. This can help avoid false alarms.

<i>UP</i>	Cycles through the choices for the selected field. For example, if Dew Point is the first displayed parameter, and parameter two and three are set to NONE, the Dew Point will be displayed. This is the factory default. For AVERAGE, if the current value is 4, pressing UP brings the value to 5.
<i>ACCEPT</i>	Pressed when the user is satisfied with all displayed values. The values are stored in non-volatile memory. Vigilant returns to the SETUP display.

3.2.3 SERIAL SETUP MENU

Figure 3-5 Serial Setup Display

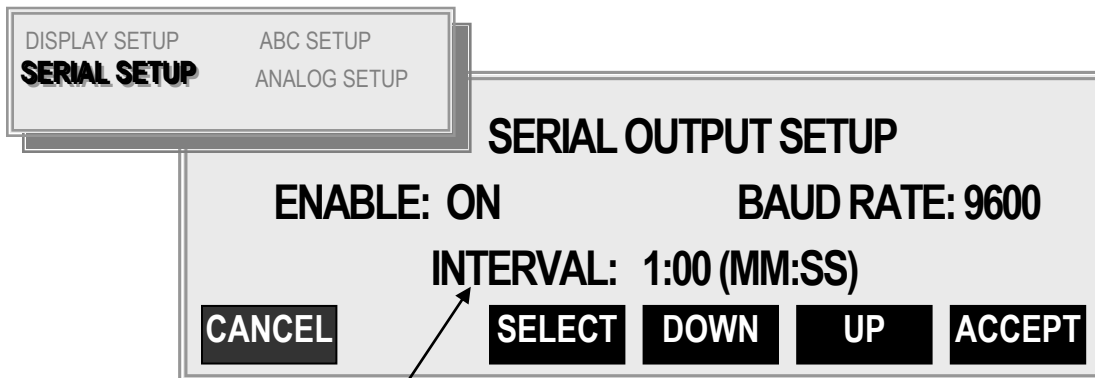

Adjusts how often samples are transmitted

The *SERIAL SETUP* display is used to select ENABLE ON or OFF, BAUD rate, and INTERVAL for data output in minutes and seconds.

Note: For proper communication, both Vigilant and the communication software need to be set at the same rate.

<u>Key</u>	<u>Function</u>
<i>CANCEL</i>	Returns to the SETUP display.
<i>SELECT</i>	Pressing SELECT advances the inverse video function selection indicator from field to field. The choices are: ENABLE, BAUD RATE, INTERVAL, then back to ENABLE.
<i>DOWN</i>	Cycles through the choices for the selected field. For example, if ENABLE is highlighted, pressing DOWN will alternate between OFF and ON.

UP Cycles through the choices for the selected field. For example, if BAUD RATE is selected, and is currently displaying 2400, pressing UP will bring 4800, 9600, 19.2 kB, then 1200 and back to 2400. For INTERVAL, the choices are 0 to 60 minutes and 1 to 59 seconds.

ACCEPT Pressed when the user is satisfied with all displayed values. The values are stored in non-volatile memory. Vigilant returns to the SETUP display.

3.2.4 ABC SETUP MENU

Figure 3-6 ABC Setup Display

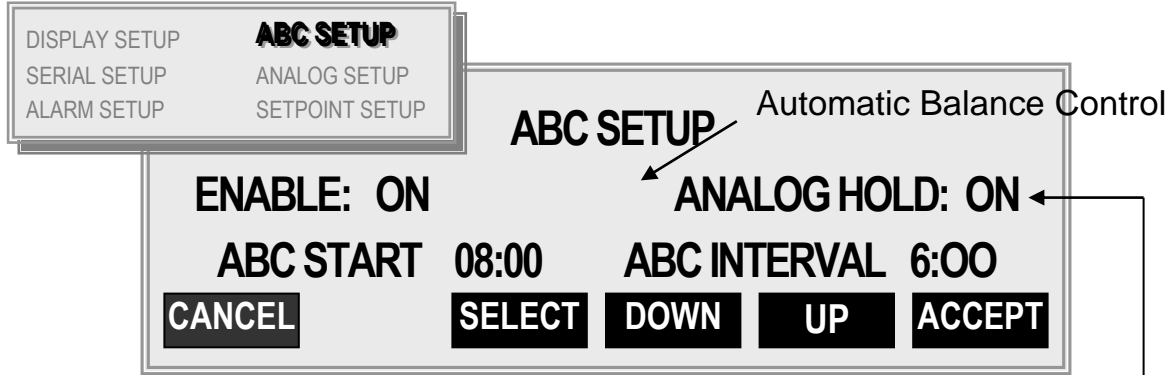

Holds analog & serial outputs at last reading before ABC cycle began until cycle is complete

The ABC SETUP display is used to ENABLE (ON or OFF) ANALOG HOLD (OFF or ON), ABC START time, and ABC INTERVAL.

<u>Key</u>	<u>Function</u>
<i>CANCEL</i>	Returns to the SETUP display with no changes.
<i>SELECT</i>	Pressing SELECT advances the inverse video function selection indicator from field to field. The choices are, ENABLE, ANALOG HOLD, ABC START, ABC INTERVAL, then back to ENABLE.

NOTE: *At user programmable intervals, Vigilant will go into an ABC Cycle to compensate for contamination on the mirror*

ANALOG HOLD If ON, the mirror temperature just before the beginning

of an ABC cycle is output on the RS-232 port and the analog output port, and held until the ABC cycle is completed. In all cases, the front-panel LCD display shows the true temperature during the entire ABC cycle. If HOLD is OFF, the display, the RS-232 output, and the analog output indicate the actual mirror temperature during the cycle.

DOWN Cycles through the choices for the selected field. For example, if ABC START is highlighted, and the initial value is 12:00, pressing DOWN will decrease the value in steps of 15 min.

UP Cycles through the choices for the selected field. For example, if ABC INTERVAL is selected, and currently displays 6:00, pressing UP increases the value in 15 min. steps.

ACCEPT Pressed when the user is satisfied with all displayed values. The

values are stored in non-volatile memory. Vigilant returns to the SETUP display.

3.2.5 ANALOG OUTPUT SETUP MENU

Figure 3-7 Analog Output Setup Display

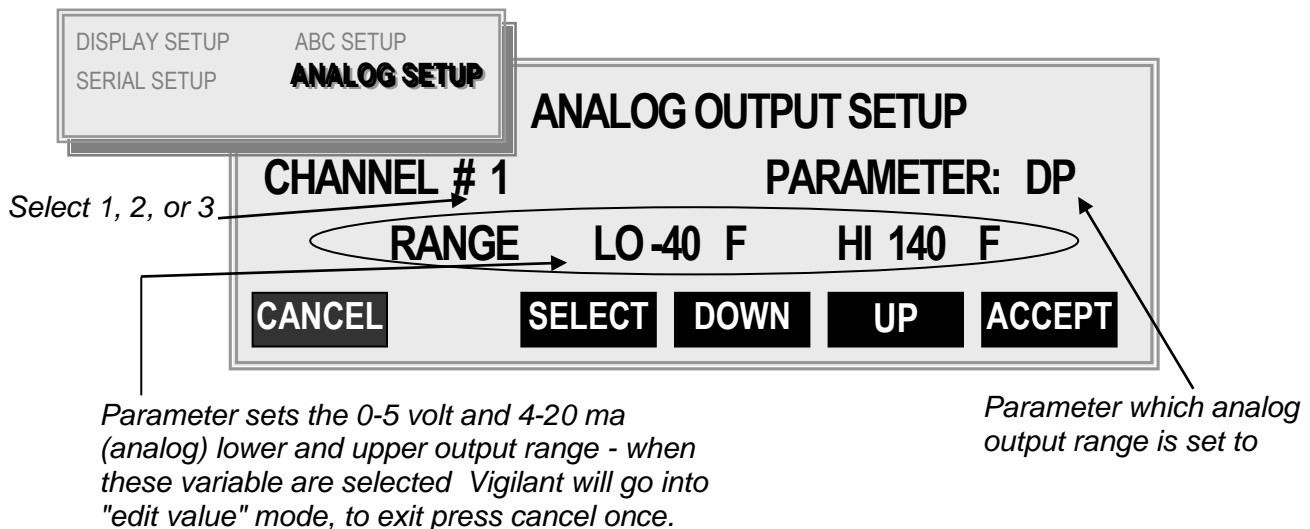

The *ANALOG OUTPUT SETUP* display is used to assign parameter(s) to the analog output channel(s). The analog output is also scaled by selecting the high and low range.

Key **Function**

CANCEL Returns to the SETUP display with no change.

SELECT Advances the inverse video function selection indicator from field to field. The choices are CHANNEL #, PARAMETER, the first digit of RANGE LO, then the second, third and fourth digit. Pressing SELECT again brings the inverse video field back to the first digit. When selecting LO and

HI range, each digit is accessed sequentially. When the HI or LO value is set to the desired value, pressing ACCEPT stores the value, and moves on to the next field.

DOWN Cycles through the choices for the selected field. For example, if the first digit of RANGE LO is highlighted, pressing DOWN will alternate between + and -. Pressing SELECT again highlights the second digit. If the initial value is 1, pressing DOWN changes the value to 0. Pressing DOWN again changes that digit to 9. After all four digits have the desired value, pressing ACCEPT stores them, and cycles to the next field.

If only one analog output channel is installed, VIGILANT only allows parameter assignments to be made to channel 1.

The RANGE LO value scales the analog output to 4 mA (current) and 0 volts (voltage output). The RANGE HI value scales the analog output to 20 mA (current) and 5 volts (voltage).

UP Cycles through the choices for the selected field. For example, if RANGE HI digit three is selected, and currently displays 6, pressing UP changes the value to 7. To move to the next RANGE HI digit, press SELECT. After all four RANGE HI digits have the desired value, pressing ACCEPT stores them, and cycles to the next field, CHANNEL #.

ACCEPT Pressed when the user is satisfied with the displayed values.

If the user is adjusting the LO RANGE, the inverse video field is advanced to HI RANGE. If the user is adjusting the HI RANGE, the inverse video advances to CHANNEL #. If the user is adjusting CHANNEL # or PARAMETER, pressing ACCEPT brings the display to SETUP. In any case, the values are stored in non-volatile memory.

3.3 SERIAL PORT SETUP

The Vigilant serial port connector located on the rear panel can be used to operate the unit, program parameters, or output data to a printer, data terminal, or personal computer. For bi-directional communications (such as with a PC or Terminal), a communication or terminal emulation software package is needed on the PC. There are many inexpensive communication programs readily available. Two such programs are HyperTerminal in Windows 95 or PROCOMM PLUS by Quarterdeck/Datastorm Corp.

3.3.1 External Device Connection

Connect an RS-232 cable between the Vigilant 9-pin female D-Type connector and the RS-232 serial port of the external device. All hardware handshaking lines are available at the connector; however a 3-wire XON/XOFF cable is all that is normally required. The serial port is wired as a DTE device (Data Terminal Equipment); i.e., Transmit (TXD) is pin 3 and Receive (RXD) is pin 2. For connection to a DCE device (Data Communications Equipment) such as a PC, a direct pin-to-pin cable can be used. For connection to another DTE device such as a printer, a null modem is required.

3.3.2 PC or Terminal Setup

Set the Vigilant to the preferred baud rate via the front panel. The available

baud rates are 19.2K, 9600, 4800, 2400, and 1200. For optimum performance, the baud rate should be set to the highest rate that the connected device can accommodate reliably. Set up the PC's communication program for a baud rate to match the Vigilant. The protocol should be 8 data bits, 1 stop bit, and no parity (N81).

3.4 RS-232 COMMANDS AND PARAMETER SETTING

3.4.1 General

Several of the setup and operating features of the Vigilant are available via the serial port. Commands can be upper or lower case. When any key is pressed, the Vigilant will respond with "Input:" and the key that was pressed "key". If the command is a single key command, pressing ENTER will initiate the command. For a two key command, press the second letter and then the ENTER key to initiate the command.

3.4.2 HELP MENU

Once communication has been established, the available commands can be viewed by accessing the HELP menu.

Type the letter "H". The display will reply with INPUT: H. Press ENTER and the HELP menu as shown in Table 3-3 will be displayed on the computer/terminal screen.

Table 3-1. HELP menu

COMMANDS	EXAMPLES (Max Entries Shown)
Start a Manual ABC Cycle.....	AB <CR>
ABC Enable Toggle	AE <CR>
ABC Start Time (HH:MM).....	AS <CR> 23:59 <CR>
Analog Hold Toggle (on/off)	AH <CR>
ABC Interval (HH:MM).....	AI <CR> 23:59 <CR>
Analog 1 Output (Min) (Max) (param)	AO1 <CR> -100 100 7<CR>
Average (Number of Data Points)	AV <CR> 16 <CR>
Enter New Date (MM/DD/YY).....	D <CR> 12/31/99 <CR>
Max Heat Toggle ON/OFF	MH <CR>
Max Cool Toggle ON/OFF.....	MC <CR>
Output Interval RS232 (Secs).....	O <CR> 3600 <CR>
Poll for Parameters.....	P <CR>
Display a Status Report.....	ST <CR>
Enter New Time (HH:MM:SS)	T <CR> 23:59:59 <CR>
Temperature Units (F, C)	U <CR> C <CR>

Press ENTER to continue.....

Notes:

When a 'param'(parameter) entry is required, set for: DP(Dew Point) = 1. Whenever a setting is changed via the serial port, the serial output times are recalculated.

Input characters are not case sensitive.

3.4.3 Start an ABC Cycle

This command initiates an ABC cycle at any time. The cycle is the same as a programmed ABC cycle.

Type the letters "AB" and press the ENTER key.

3.4.4 ABC Enable

Type "AE" and then ENTER to alternately enable or disable the timed ABC function. The start time and interval settings will not be changed.

NOTE: Two digits must be used for each entry field.

3.4.5 ABC Start Time

Type the letters "AS" and press the ENTER key. Enter the time "Hours:Minutes" in 24 hr. format, and press the ENTER key.

Examples: "02:00", is 2:00 AM: "14:30" is 2:30 PM.

3.4.6 ABC Interval

Type the letters "AI" and press the ENTER key. Type the time in "Hours:Minutes" and press the ENTER key.

Example: If the ABC Start Time is 08:00 o'clock in the morning and the ABC Interval is 02:00, the first ABC cycle for the day would occur at 8:00 AM and every two hours thereafter.

3.4.7 ABC Analog Hold

Typing the letters 'AH' will toggle the

ABC Hold feature on or off. If ABC Hold is on, the analog and serial outputs will be held at the values just prior to initiating the ABC Cycle. The serial output will contain the message "ABC Hold". The hold will be released when the ABC Cycle is complete and the instrument has stabilized back on the dew point.

3.4.8 Number of Data Samples to Average

This command sets the number of data samples to average. Data is sampled once per second. Therefore, a number of 4 would display a 'rolling average' for the last 4 seconds. The limits are 1 to 16 samples.

Type the letters "AV" and press the ENTER key. The Vigilant will respond with "Enter SETTING =." Type the two-digit value and press the ENTER key.

3.4.9 Analog Output (Low) (High) (param)

This parameter sets the 0-5 volt and 4-20 mA (analog) lower and upper output ranges and the parameter for each of three output channels. The instrument range is -75 to +100°C.

A plus (+) sign is not needed for positive temperature entries, but a minus (-) sign is necessary.

Type the letters "AO1" for channel one, and press the ENTER key. Enter the limits with a minus sign first (if negative), then the lower limit, a space, the positive or negative upper limit, a space, and the parameter number.

Press the ENTER key to record the values.

Example:

Entering "-33 45 2" sets a low value of -33°, a high value of +45°, and a parameter of Ambient Temperature (2). The units, C or F, will be whichever is active at the time of the setting. If the units are changed later, all affected parameters will be set to the new units.

3.4.10 Date

Type the letter "D" and then press ENTER.

The DATE format is:
MONTH/DAY/YEAR

"01/01/00" = January 1, 2000

"12/31/99" = December 31, 1999

NOTE: Two digits must be used for each entry field and separated by a backslash character. The Vigilant internal date software is fully year 2000 compliant.

3.4.11 Output Interval

This is the interval in seconds between automatic data output transmissions of the serial data output. The time range is from 0 to 3600 seconds.

Type the letter "O" and press the ENTER key. Enter the desired interval in seconds and press ENTER.

3.4.12 Poll for Output

This command requests the Vigilant to send serial data at any time and is independent of the automatic interval.

Type the letter "P" and press the "ENTER" key.

3.4.13 Manual Heat

This command toggles the Sensor's heater on or off. It can be initiated at any time and can be used to clear excessive moisture from the mirror in flooding situations.

Type the letters “MH” and press the ENTER key. The Vigilant will display a flashing MAN MAX HEAT and the temperature will rise. To turn off the MANUAL HEAT mode, enter “MH” again.

3.4.14 Manual Cool

This command toggles the Sensor’s cooler on or off. It can be used to test the maximum depression of the Sensor.

Type the letters “MC” and press the ENTER key. The Vigilant will display a flashing MAN MAX COOL and the temperature will decrease. To turn off the MANUAL COOL mode, enter “MC” again.

NOTE: After an extended period of time in the cool mode, excess moisture or frost will form on the mirror. It may be necessary to “Manually Heat” the mirror to shorten the drying time.

3.4.15 Time

Type the letter “T” and press ENTER. The time format is: Hours: Minutes:

Seconds. Hours are expressed in 24-hour military time.

Enter the desired time with colon delimiters:

Examples:

“00:00:00” = 12 midnight

“23:59:59” = 11:59:59 pm

3.4.16 Units (F,C)

The Vigilant can display temperature in either Degrees C or Degrees F. The display and RS-232 data will reflect the selection.

Type the letter “U” and press ENTER. Type “C” or “F” and press ENTER.

3.4.17 Status Report

This command gives the user a report of all of the current settings. To get a status report, do the following.

Type the letters “ST”. The display will show: Input: ST. Press the ENTER key. The following sample status report will display.

VIGILANT System Status Report

ABC data:	State	Start Time	Interval	Hold
	ENABLED	0:00:00	2:00	OFF

ANALOG data: #	Item	Low	High
1	DP	-20.00 C	40.00 C

DISPLAY data:	Left	Middle	Right	Average
	DP	PPMV	GR	4

SERIAL data:	Baud	Interval	State
	9600	1:00	ON

Press ENTER to continue.....

4.0 THEORY OF OPERATION

4.1 SYSTEM OVERVIEW

The 137 Vigilant System consists of four main functional blocks, the main control loop, the data acquisition function, the mirror temperature control loop, and the Automatic Balance Cycle (ABC) function. All of the functions are controlled and supervised by the on-board microprocessor running under software control.

4.1.1 Main Control Loop

The Vigilant Dew Point Hygrometer measures the dew point of the sample air by cooling a reflective metal surface. When the surface temperature reaches the dew point temperature of the air, a layer of dew begins to form on the surface. An LED light source focused on the chilled surface and reflected onto a photo-detector. The change in reflected energy as dew forms is sensed by the photo-detector and used to control the surface temperature and maintain a constant dew layer. The software controlled servo loop monitors the reflected optical energy and continuously adjusts the Thermo-Electric Cooler (TEC) power to maintain a constant optical level.

4.1.2 Data Acquisition

The temperature of the mirror surface is measured with a Platinum Resistance Thermometer (PRT) element embedded beneath the mirror surface. The Vigilant temperature measuring circuits for Dew Point and Ambient Temperature use a three-wire connection. A software algorithm then computes the four wire equivalent resistance with virtually the same accuracy and immunity to cable length as a true four-wire system.

Under microprocessor control, the output of the PRT element is amplified, digitized, and displayed once per second. Once digitized, the signal is linearized, scaled via software, and displayed on the front panel in degrees C or F. The digital value can then be used to monitor RS-232 digital outputs. Twelve bit Digital to Analog Converters (DAC) are used to produce the analog outputs. The PRT amplifiers in the Vigilant are automatically adjusted for span and zero every few seconds under computer control and do not require periodic adjustments.

When the Vigilant enters an Automatic Balance Cycle (ABC), the control loop is interrupted and the mirror is heated to a temperature well above the dew point. After a length of time at elevated temperature, the mirror is assumed to be dry and the optics intensity is adjusted to a reference value. The adjustment compensates for reflectivity changes in the optics path due to contamination of the mirror surface or aging of the optics components since the last ABC cycle.

4.1.4 Automatic Balance Cycle (ABC)

The Automatic Balance Cycle (ABC) is initiated upon instrument turn-on. In addition, the ABC can be initiated automatically at programmable intervals, or initiated manually at any time by depressing the MABC (Manual Automatic Balance Cycle) key on the keypad, or remotely via the RS-232 port.

The ABC begins by heating the mirror to a temperature well above the dew point to evaporate any dew on the surface. The computer determines that the mirror is dry and ready to be re-balanced based

on a pre-set time interval AND the stability of the mirror reflectance. The pre-set time interval is determined by the mirror temperature at the beginning of the cycle. At low temperatures, greater time is needed to heat the mirror and evaporate the condensate. If the mirror temperature at the beginning of the cycle is greater than -20°C , the heat time is a minimum of 1.0 minute. If the temperature is below -20°C , the heat time is a minimum of 3.0 minutes.

At the end of the heat phase, the computer balances the optical bridge and control loop and returns to normal operation. If, at the end of an ABC, the amount of balance adjustment is too large, a flashing “CLEAN MIRROR” message will appear on the display and the serial output. If the computer finds any other abnormality in sensor performance during an ABC, a flashing “CHECK SENSOR” message will appear in which case the factory should be contacted.

5.0 MAINTENANCE AND CALIBRATION

5.1 ROUTINE MAINTENANCE

To ensure the maximum in accurate and reliable operation of any optical chilled mirror system, a periodic maintenance program should be established.

5.2 MIRROR CLEANING SCHEDULE

The buildup of contamination on the mirror surface normally occurs very slowly. Over time, particulate and other matter present in the sample gas and not captured by filters, build up on the mirror. The result of the buildup of contaminants on the mirror surface is reduced dry mirror reflectivity and a change in the optical reference point. The ABC Cycle will automatically readjust the reference point periodically, but eventually the adjustment range will be exceeded and a manual cleaning of the mirror may be necessary. When the contamination becomes too severe to be adjusted automatically, an error will be displayed at the end of the ABC Cycle. Normally, intervals of 90 days between routine mirror cleanings can be easily achieved. However, if the sample contaminants are particularly high, more frequent mirror cleanings may be required. When cleaning is required, clean the mirror surface and optical parts.

5.3 MIRROR CLEANING

To clean the mirror surface:

- 1 Disassemble the Sensor to expose the mirror. See Figures 5-1 and 5-2.

Note: Be careful not to misplace the thin washer located inside the large screw-on nut shown at the left in Figure 5-1.

- 2 Press the “HEAT” key on the front panel to heat the mirror and evaporate any condensate.



Figure 5-1 Mirror access

- 3 Rotate the cylindrical sensor cover to expose the mirror surface.
- 4 Moisten a clean cotton swab with isopropyl alcohol. Cotton swabs and cleaning bottle are provided in the Cleaning Kit shipped with the system.

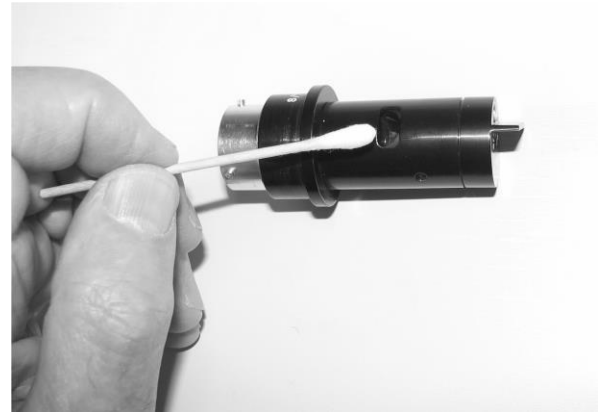

Figure 5-2 Cleaning the mirror

- 5 Wipe the mirror surface and the optics surface in a circular motion.
- 6 After cleaning the mirror surface, wipe the surfaces dry with a clean cotton swab.
- 7 Next, moisten a clean cotton swab with clean, preferably distilled water and wipe the mirror and optics areas.
- 8 Dry these areas thoroughly with a

clean, dry cotton swab.

- 9 Reassemble the sensor.

Note: Be sure that the flat tab on the end of the sensor fits properly into the slot inside the white sampling probe. The sensor can only go in one way.

- 10 Press the “HEAT” key to return normal operation.
- 11 Turn the instrument off for two seconds and then on again. As the sensor warms up in the ABC HEAT mode, observe the optics condition bargraph on the display. The bar should be steady and approximately centered. If the bargraph is less than 10% or more than 90%, a manual Sensor Balance is recommended. Press the MABC button on the front panel.

5.4 CALIBRATION OF THE PRT

A Platinum Resistance Thermometer (PRT) is used in the dew point sensor to measure the mirror temperature, which tracks the dew point temperature. The Vigilant electronics has an integral auto-zero and auto-slope adjustment and requires no manual adjustments. However, if a problem is suspected, the accuracy can be checked using the PRT AMPLIFIER CHECK Procedure.

5.5 PRT AMPLIFIER CHECK

If a problem is suspected in the accuracy of the Dew Point Temperature, the following procedure is recommended:

1. Remove the Sensor from the end of the cable and prepare a precision resistance decade box to be used to simulate the PRT in the Sensor.
2. Remove the top cover as shown in Figure 5-3.
3. Set the resistance decade box to

100.00 ohms.

4. Using three equal lengths of the same gauge wire, connect pins 4 and 10 of the connector to each other and to one terminal of the decade box. Connect the other terminal of the decade box to pin 9 of the Sensor cable connector.
5. Turn power on to the instrument. The front panel display should be reading 00.0°C at this time.
6. Set the resistance decade box to 119.40 ohms. The display should read +50.0°C +/- 0.2°C.
7. Set the resistance decade box to 88.22 ohms, a display of -30°C +/- 0.2°C.
8. Once the check has been completed, remove the resistance decade box and reattach the Sensor to the end of the cable. Re-attach the Control Unit cover to the chassis.

5.6 OPERATING ADJUSTMENTS

The Vigilant is designed to operate with a minimum of adjustments or user attention. However, certain adjustments may be required from time to time. The following adjustment procedures are meant to be performed by trained technicians and should not be attempted by untrained personnel.

See Figures 5-3 and 5-4.

To remove top cover B

1. Remove 4 screws: 2 of the #6 screws and 2 of the #4 screws marked BB on the control box.
2. Slide cover from front to back in direction of arrows.

To remove bezel A

1. Remove 4 screws: 2 of the #6 screws marked AA and 2 of the #6 screws

- marked **BB** – if not previously removed.
 2. Carefully pull assembly away from

chassis so as not to break cables. To disconnect bezel completely, remove ribbon cable and power connectors.

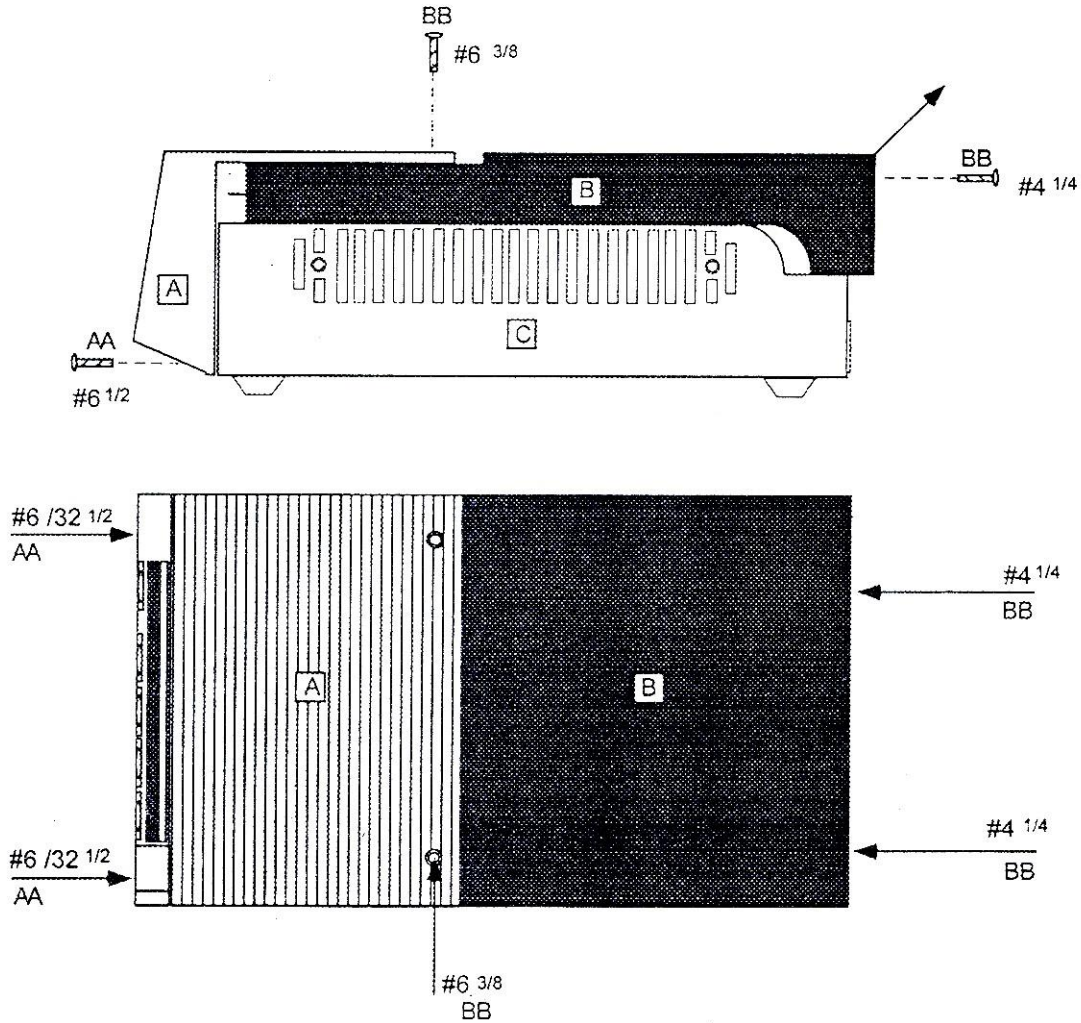

Figure 5-3 Enclosure Cover and Bezel Removal



Figure 5-4 View of Interior with Top Cover Removed

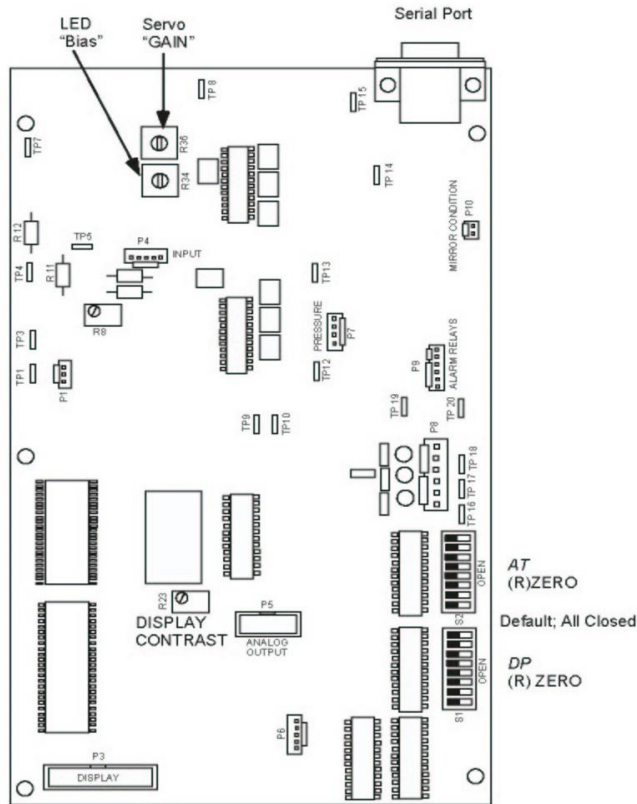

Figure 5-5 Main PC Board

5.6.1 Servo Gain

The servo gain adjustment affects the stability of the servo loop, particularly at high dew points. If the dew point is unstable or appears to oscillate, the gain may need to be decreased. A sluggish or slow response indicates a higher gain is required. The GAIN control adjusts the overall gain of the servo control loop. It is set at the factory to provide stable operation over the range of operation of the instrument. Before making adjustments to the GAIN control, always record the factory-set position to aid in returning to the original position at a later date.

1. Remove top cover as in Figure 5-3.
2. Rotate R36 clockwise to increase gain or counter clockwise to decrease.
3. Wait about a minute between adjustments to allow the servo loop to stabilize with the new gain.
4. Replace top cover.

5.6.2 LED BIAS

The LED Bias adjust is pre-set at the factory and should not require readjustment. Consult the factory for further information.

5.6.3 RZERO Adjust

The RZERO adjustment is used to compensate for differences in initial accuracy between sensor PRT's. The most common application of this feature is when a replacement sensor is purchased separately from EdgeTech. The Vigilant RZERO is a digital offset applied via the software. The adjustment is made with an eight-position binary coded DIP-switch. Position 1 is the sign bit and positions 2 through 8 are data bits. One lsb (least significant bit) is

equal to 0.01°C.

The certificate supplied with the new sensor will contain the new setting in binary code for the RZERO DIP-switch.

1. To change the setting of the DIP-Switch:
2. Remove top cover and Front Panel Bezel Assembly as in Figure TOP.
3. Locate DIP-switch **S1** (for dew point) in Figure MAIN PCB.
4. Set DIP-switch according to supplied data.

Example: The number positions from left to right are equivalent to positions 1 to 8 of the switch. The switch is marked open(1) on one side while the opposite side represents closed(0).

The new setting for a code of 01001011 is: 1=closed, 2=open, 3=closed, 4=closed, 5=open, 6=closed, 7=open, 8=open.

5.6.4 Display Contrast

The display contrast is adjustable with potentiometer **R23**. The adjustment can be done in any operating mode.

1. Remove top cover as in Figure 5-3
2. Locate **R23**.
3. Adjust **R23** for the desired appearance.
4. Replace top cover.

6.0 SPECIFICATIONS

Dew/Frost Point Range

-40* to +60°C (-40 to +140°F) A1
Sensor
-50* to +90°C (-58 to +200°F) A3
Sensor

Dew/Frost Point Accuracy

±0.20°C (±0.36°F) nominal

Dew/Frost Point Sensor

3-wire Platinum Resistance
Thermometer (PRT), 100 ohms at 0°C,
nominal

Depression

45°C (81°F), nominal, A1 Sensor
65°C (117°F), nominal, A3 Sensor

Sensor Materials

Chromium, glass, epoxy, anodized
aluminum

Slew Rate

1.5°C (2.7°F)/second max, above 0°C

Repeatability

±0.05°C (0.09°F)

Hysteresis

Negligible

Precision

0.1 degrees C or F

Sample Flow Rate

0.25-2.5 liters/minute (0.5-5.0 SCFH)

Operating Temperature

Control Unit: 0 to +50°C (+32 to +122°F)
A1 Sensor: -40 to +60°C (-40 to 110°F)
A3 Sensor: -50 to +100°C (-58 to 212°F)

Display

LCD graphics backlit display
0.25-in. high digits

Keypad

Five soft keys for setup and operation:
Displayed parameter selection: °C/°F
toggle: View/change time, date: digital
averaging: baud rate: Manual Auto
Balance Cycle initiate: Program Auto
Balance Cycle for start time, interval,
output Track/Hold: Maximum Heat
toggle: Maximum Cool toggle:
View/change high and low limits for
analog outputs: View/change Alarm
parameters, high/low limits, high or low
alarms, latched or unlatched relays,
Reset front panel Alarm indicators
(latched only).

Analog Output

Voltage

0 to 5 VDC, scaleable from -75 to
+100°C (-103 to +212°F)
1 K ohms minimum load resistance

Current

4 to 20 mA, scaleable from -75 to
+100°C (-103 to +212°F)
1000 ohms maximum loop resistance

Serial Digital Communication

RS-232C compatible
9-pin D sub-miniature connector (female)
Baud Rates:
1200/2400/4800/9600/19200 Protocol:
N81
Output of time, date and dew/frost point
at timed intervals
Programming of most keypad functions.

Mirror Condition

Rear panel TTL output and front panel
display.

Auto Balance Control:

Manual initiation of ABC at any time
Automatic ABC with start time and

interval programmable from keypad or RS-232 port.
Outputs programmable for Track or Hold during ABC.

Physical:

Shipping weight:
11 pounds (5 kg) with sensor.

Dimensions:

Less shock mount base (LxWxH):

13 x 7.6 x 4.9 inches

(33 x 19.2 x 12.4 cm)

With shock mount base (LxWxH):

13.1 x 7.6 x 5.8 inches

(33 x 19 x 14.6 cm)

Power Requirements:

90 to 240 VAC, 50-60 Hz,
75 watts maximum

Fuses:

90 - 150 VAC Operation:
1A, 3 AG, 250 VAC, Slo-Blo
160 - 240 VAC Operation:

Option:

Air Temperature Sensor:
3 wire Platinum Resistance
Thermometer (RTD)
A.T. Accuracy: $\pm 0.2^{\circ}\text{C}$
RH Accuracy: $\pm 0.5\%$ typical
Sampling Range: 1/sec

7.0 INSTRUMENT OPTIONS

Note:

**Available only on Special Orders.
Consult Factory for information.**

7.1 Parameters

The basic unit measures Dew Point. Optional parameters include Ambient Temperature, RH, PPMV, Gr/lb, and Wet-bulb. Consult factory for additional parameters.

7.2 Analog Outputs

Two additional outputs are available for a total of three programmable, 4 – 20 mA and 0 – 5VDC channels.

7.3 Isolated Analog Outputs

Three channels of isolated 4-20 mA and 0-5 VDC are available for applications requiring ground isolation between the Vigilant and the user's equipment. Maximum loop resistance is 1000 ohms.

7.4 Alarm Relays

The relay option consists of two form C relays which can be independently set for high or low limit and any measured parameter. When an alarm condition occurs, a flashing message appears on the display as well as the activation of the relay. The alarm conditions can be setup via the front panel or the RS232 serial port.

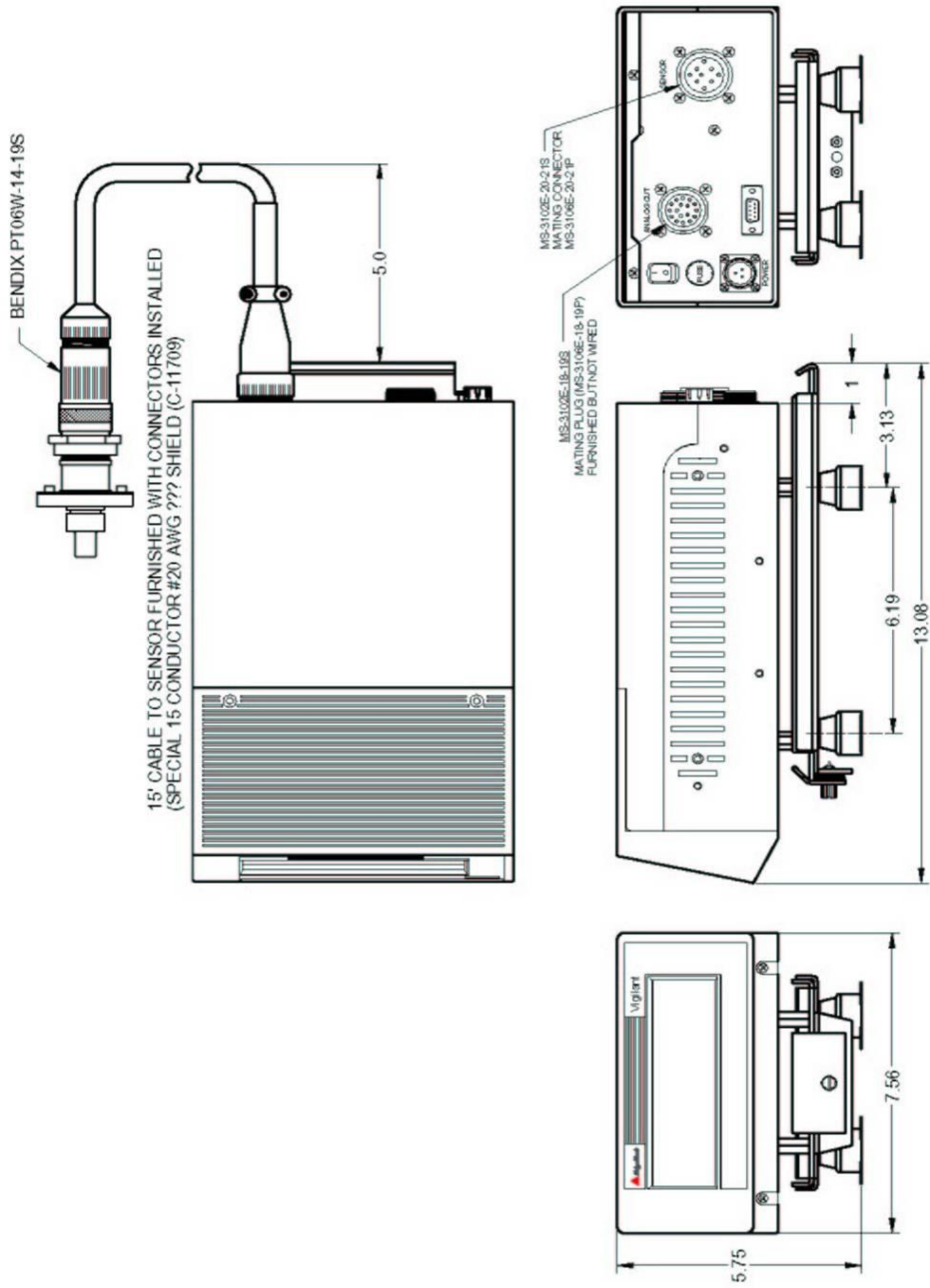

A. Hygrometer Control Unit, Installation Requirements

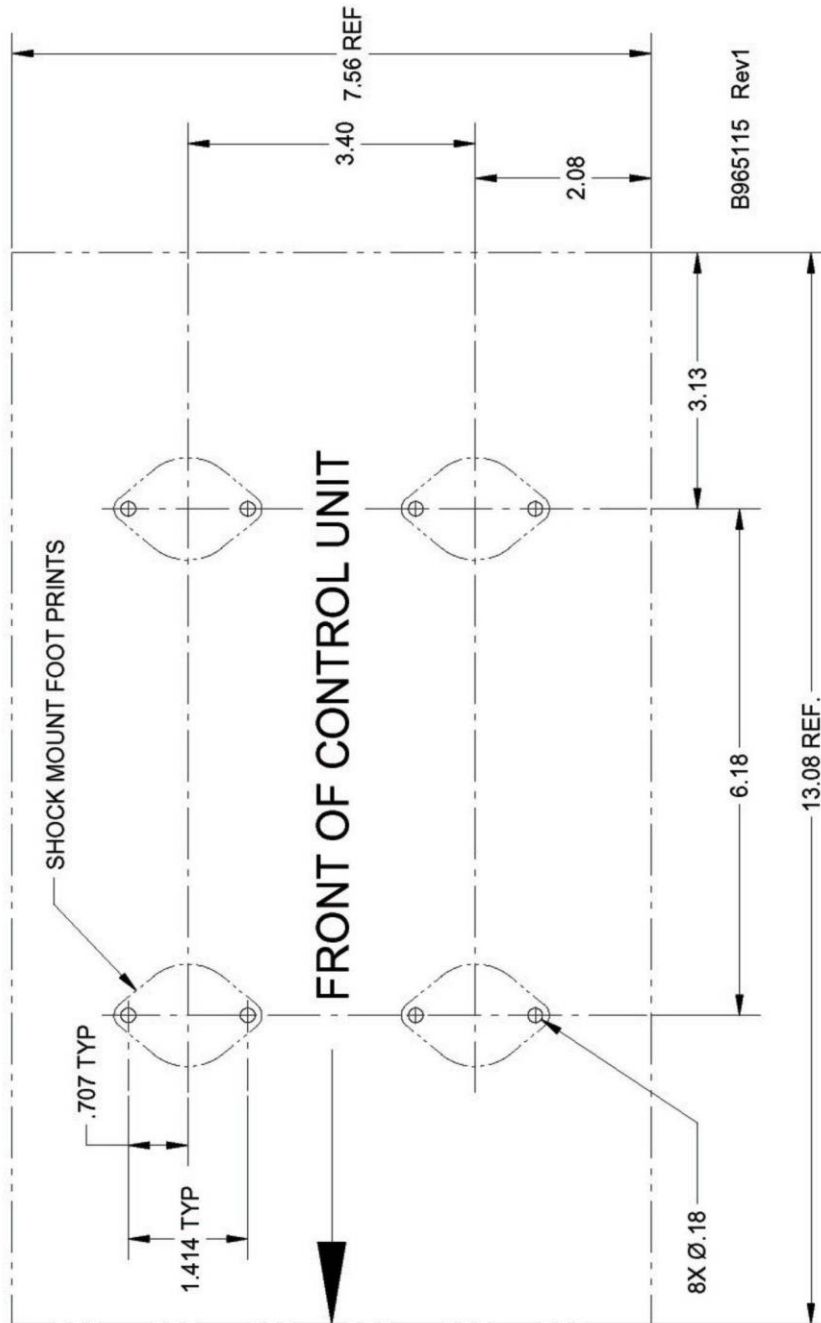

B. Instrument Mounting Dimensions

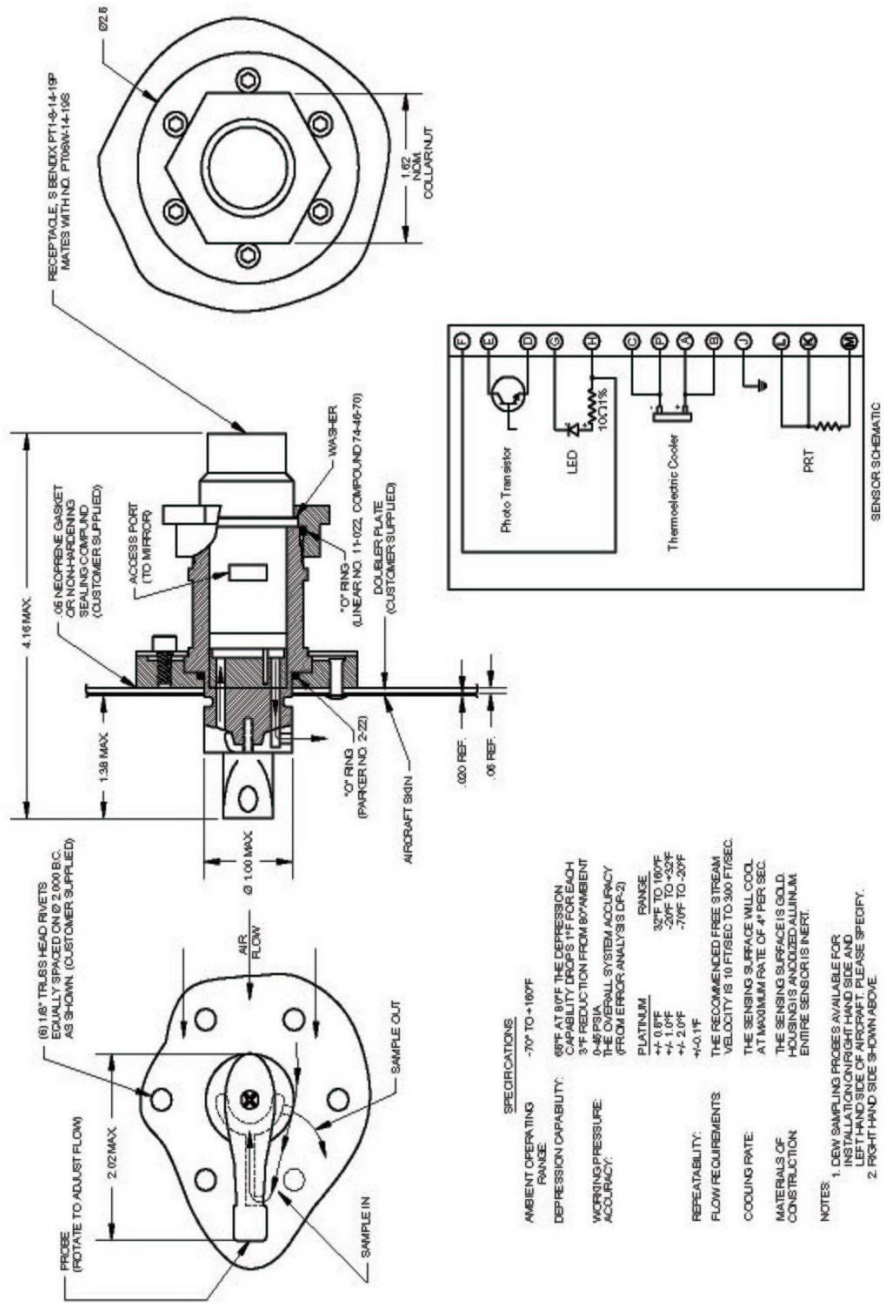

C. Sensor Unit, Configuration Control Drawing

Notes