



SERIES DewTech 390

MODEL CMH-DM-RS

OPERATORS MANUAL



Edgetech Instruments Inc.

399 River Road • Hudson • MA USA 01749

Tel. +1 [978] 310-7760 • +1 [800] 276-3729 • Fax +1 [978] 310-7767

E-mail h2o@edgetechinstruments.com • www.edgetechinstruments.com



Safety Information

The **Model CMH-DM-RPC** is designed to be connected to electric voltages (120 - 240V) and protected by a 13amp fused plug to the main power supply.

The Model CMH-DM-RPC must be electrically grounded to earth.

Check to establish that all wiring and connections are not damaged. If damage is observed to any electrical wiring or damage to the apparatus, they must not be connected to the mains supply and returned to Edgetech Instruments Inc.



Warnings

Risk of electric shock - Do not open any part of the enclosures of the **CMH-DM-RPC** or any electrical apparatus while connected to the mains supply.

Do not connect the **CMH-DM-RPC** or any electrical apparatus to the mains supply until they are in their permanent positions.

Ignoring this safety information can result in severe personal injury and/or mechanical damage to the **CMH-DM-RPC**.

The product specifications must not be exceeded at anytime as this may cause damage to the Unit or cause risk of damage or fire.

Do not connect the **CMH-DM-RPC** to any other device that is not recommended in this manual.

If in any doubt - call **Edgetech Instruments**.

Ensure that the **CMH-DM-RPC** does not come into direct contact with water or any other liquids.

To avoid the risk of electric shock, risk of damage or fire these safety instructions and guidelines must be followed. Only qualified personnel/technicians should install this instrument to the mains supply and ensure it is safe before use.



Safe Isolation

Switch off at the mains power supply and remove the plugs before any maintenance is carried out by a qualified person. Always test components with an approved voltage meter before handling to ensure it is completely dead.

YOU MUST ALSO READ THE SAFETY INFORMATION ON PAGES 16 and 38



This is a step by step instruction manual to help you successfully and correctly set up the Model CMH-DM-RPC before use.

This manual should be kept with the Model CMH-DM-RPC for future reference.

You must also observe the safety information on pages 16 and 38 before installation.

Please read this manual carefully from the start.

Intended Use:

The Edgetech Instruments Dewtech 390 Series of Instruments utilize a three stage peltier cooled mirror hygrometer and integral refrigeration unit. The Series 390 is a useful and dependable line of instruments designed to provide years of services to precisely measure moisture as low as -90°C (-130°F) dewpoint (T_d) in air and inert gases. The series 390 is not designed for use with flammable gases nor should the instrument be mounted in areas know to contain hazardous gases. If you have any questions or comments regarding the installation, use or maintenance of this instrument, please do not hesitate to contact our customer service department. You may reach us at +1 (800) 276-3729 or by email at h2o@edgetechinstruments.com

© 2014 Edgetech Instruments, Inc.

Index

Introduction	6
Model CMH-DM-RPC Functional Description	7
General Overview	7
Chilled Mirror Model CMH	7
Cooling Unit – RPC	7
Temperature Controller	8
Temperature Controller Factory Default Settings	9
Front Panel Diagram of DewMaster Panel	10
Rear View Diagram of DEWTECH 390 & DewMaster	11
Mirror Balance	12
Programmable Functions	12
The ABC Cycle	12
Serial Port	12
The Data Output Function	12
The Control Function	12
Analogue Outputs:	12
Alarm Relays:	12
Programmable Functions Continued	13
Isolated 4-20mA Output:	13
Specifications	14-15
Installation – Unpacking	16
Mounting	16
General	16
Temperature Limits	16
Wiring Connections	16
Safe Isolation	16
Sample Connections	17
Sampling Configurations	17
Sampling Configurations – Continued	18
Selection Of Components At Low Dew Points	19
Pressure Measurements	19
Sample Flow Rate	19
Information Display Functions	20
Operating the Dew Master	21
Information display in detail	21
Time and Date	21
System Status	21
Main Displays	21
Bar Graph	21
Information display in detail - continued	22
System Status	22
Main Displays	22
Programming the Dew Master	23
Scroll Menu (Using the Arrow Keys)	24
Display Setup	24
Sample Averaging (1-16)	24
Analog Output	25
ABC Cycle	25
Alarm Relay 1	25
Programming the Alarm Relay 1 Setpoint	25
Locking In the Programming Changes	25
Programming the Serial Port	26

Serial Output	26
External Device Connection	26
PC or Terminal Setup	26
RS-232 Commands and Parameter Setting	26
General	26
Help Menu	26
Help Menu Table	27
Start an ABC Cycle	27
ABC Enable	27
ABC Start Time	28
ABC Internal	28
ABC Analog Hold	28
ALARM 1 AND (OPTIONAL) ALARM 2	28
Alarm 1 and Alarm 2 Latches	29
Number of Data Samples to Average	29
Analog Output (Low) (High) (Param)	29
Setting the Date	29
Output Interval	29
Poll for Output	30
Manual Heat	30
Manual Cool	30
Time	30
Units (F,C)	30
Status Report	30
DewMaster System Status Report	31
Help Menu Table.	32
Baud Rate	33
RS-232 Output Interval	33
Default Programmable Parameters	34
System Operation	34-35
Temperature	35
Automatic Mirror Balance Control (ABC)	35
Microprocessor Control	35
Circuit Descriptions	36
Thermoelectric Dewpoint Temperature Control Circuit	36
Sensor PRT Resistance-to-Voltage Converter	36
Automatic Mirror Balance Control Circuits	36-37
Alarm Set	37
Display	37
Track or Hold Circuit	37
Routine Maintenance	37
Mirror Cleaning Schedule	38
Mirror Cleaning	38-39
Calibration of PRT	39
Calibration of the PRT amplifier	39-40
Operating Adjustments	40
Optical Adjustment Procedure	40
Gain	40-41
Suggested Spares	42
Trouble Shooting	42-44
Test Points	45
Contact Information	46
Warranty Statement	47

Introduction

Thank you for purchasing an **Edgetech Instruments Model CMH-DM-RPC**

We are sure that you will agree that the **CMH-DM-RPC** is easy and friendly to use, reliable and accurate.

At **Edgetech Instruments** we are committed to customer satisfaction, through continuous Research and Development, Quality and Customer Service. We encourage all our customers for feedback on our products and services, so please feel free to leave any comments or feedback at h2o@edgetechinstruments.com

The Model Number **CMH-DM-RPC** stands for **Chilled Mirror Hygrometer incorporating a **Dew Master Control Panel and a Refrigerant Pre Cooler.****

Your **CMH-DM-RPC** has the most reliable quality components installed, the instrument has been hand built to your specification by our time served dedicated technicians. The components have undergone rigorous testing to ensure that you get the reliability, peace of mind and confidence you would expect from any **Edgetech Instruments** products.

You will notice that we have abbreviated the full part number to **CMH** and/or **DM** on occasions throughout the manual.

Please read the safety instructions carefully and call **Edgetech Instruments** Technical department should you be unclear on any point of this manual. +1 (800) 276-3729

Thank you.

The **Edgetech Instruments** Team.

Model CMH-DM-RPC Functional Description

General Overview

The **CMH-DM-RPC** Instrument is designed to measure gas moisture as low as -90°C dewpoint. It comprises a standard Edgetech Instruments S3 three stage peltier cooled mirror hygrometer which gives a 95°C temperature depression across the peltier battery at 25°C with remote sensor and a fan cooled refrigerant condensing unit together with a temperature controller and associated electronics.

Chilled Mirror Model CMH

The **CMH** is available in two major configurations:

1. The CMH is a dewpoint instrument with the addition of pressure measurement to compute moisture concentration values, in ppm(v) as standard.
2. Can display concentrations at atmospheric pressure or an input from a pressure transducer to compensate for pressure variations. To measure low dewpoints, the hot junction of the peltier battery is pre-cooled to -35°C .

To achieve this, a refrigerant pre-cooler (**RPC**) is used. The refrigerant expansion is designed to occur directly at the base of the peltier battery giving optimum and accurate cooling.

At higher dewpoints the peltier base temperature is controlled at $+20^{\circ}\text{C}$. The **CMH** alarm 1 relay is set to close at $<-45^{\circ}\text{C}$ dewpoint, at which point the peltier base temperature is controlled at -35°C .

Using a primary measurement technique, the **CMH** is ideal for laboratory, scientific, and research applications, and can be equipped with a mirror microscope when used as a calibration standard.

Equipped with provisions for self-checking and automatic mirror balancing, the **Model CMH** can verify its own performance on a timed sequential basis, making it suitable for process control and continuous unattended operation.

Cooling Unit - RPC

The cooling unit comprises a compressor and fan cooled condensing unit along with expansion and pressure release (return) valves. The refrigerant expansion valve is a mains powered solenoid valve intended for repetitive operation and driven by the Solid State Relay (SSR).

Since the compressor and cooling fan run continuously, the situation arises when the expansion valve is off for long periods and the compressor has nothing to pump. This is especially true when running at Set Point 1. When this happens, the timer drives the return valve (which bypasses the expansion valve) and returns refrigerant to the compressor input.

The timer is set to operate for 1 second and then break for 30 seconds.

Temperature Controller

IT IS GENERALLY RECOMMENDED THAT NO ADJUSTMENTS BE MADE AT THE TEMPERATURE CONTROLLER WITHOUT THE ADVISEMENT OF EDGETECH INSTRUMENTS TECHNICAL STAFF.

The temperature controller is mounted on the front panel of the auxiliary cooling module. Its operation is fully automatic and does not need to be adjusted.

A 'T' type thermocouple is mounted in the wall between the peltier battery and the refrigerant expansion chamber. The thermocouple is read by the temperature controller, which displays the measured temperature in its top display.

The refrigerant expansion valve is controlled by the controller output, through the mains rated, solid state relay.

Full PID control of the temperature is achieved by PWM control of the output. The PWM period is set to 4 seconds, and the duty cycle range of 15% max. The control set point is +20°C (Set point 1) except when Alarm 1 on the **CMH** has tripped. In this event, the switch closure of the alarm relay is used to change the set point to -35°C (Set point 2). The instrument's lower display indicates the current set point.

A concise product manual for the controller is attached on the next pages, for information and trouble-shooting purposes.

The tables on the next page give the factory setting for the instrument.

Temperature Controller Factory Default Settings

1) Configuration Mode - Unlock Code 20

Note: If any values are changed then the AUTO/MAN key must be pressed after each change to accept the new value.

Parameter	Value
Input Range/Type	t.C
Scale Range Upper Limit	50.0
Scale Range Lower Limit	-50.0
Control Type	SnGL
Primary Output Control Action	dir
Alarm 1Type	P_Hi
High Alm 1 value	30
Alm 1 Hysteresis	0.1
Alarm 2 Type	P_Lo
Low Alm 2 value	-42
Alm 2 Hysteresis	0.1
Loop Alarm	disA
Alarm Inhibit	none
Output 1 Usage	Pri
Display Strategy	2
Digital Input Usage	diS1
Config Lock Code	20

2) Automatic Tuning mode

Parameter	Value
Pre-Tune	OFF
Self-Tune	OFF
Tune Lock	0

3) Setup parameters - Unlock Code 10

Note: Any alterations in this menu are automatically changed.

Parameter	Value
Input Filter Time constant	0
Process Variable Offset	0
Primary (Heat) power	Read Only (Cannot be set from here)
Primary Proportional Band	20 (As set on delivery)
Automatic Reset (Integral Time)	OFF
Rate (Derivative Time)	0.05
Manual Reset (Bias)	0
Setpoint Upper Limit	50.0
Setpoint Lower limit	-50.0
Primary Output Power Limit	20%
Output 1 Cycle Time	4
High Alarm 1 value	30
Alarm 1 Hysteresis	0.1
Low Alarm 2 value	-42
Alarm 2 Hysteresis	0.1
Auto Pre-tune	DISA
Auto/manual Control selection	EnAb
Setpoint ramping	DISA
SP Ramp Rate Value	Blank (Set above 99.99)
SP1 Value	+25
SP2 Value	-35
Setup Lock Code	10

FRONT PANEL OF DEWMASTER

FRONT PANEL OF DEWTECH 390

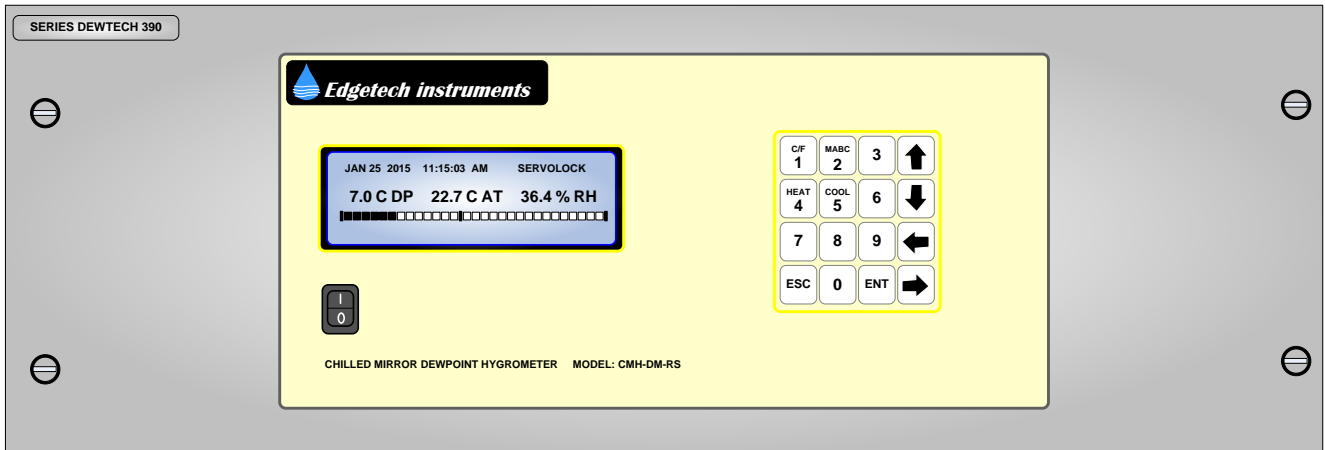

NOTES:

REAR VIEW OF DEWTECH 390 and DEWMASTER CONNECTIONS

DewMaster REAR PANEL

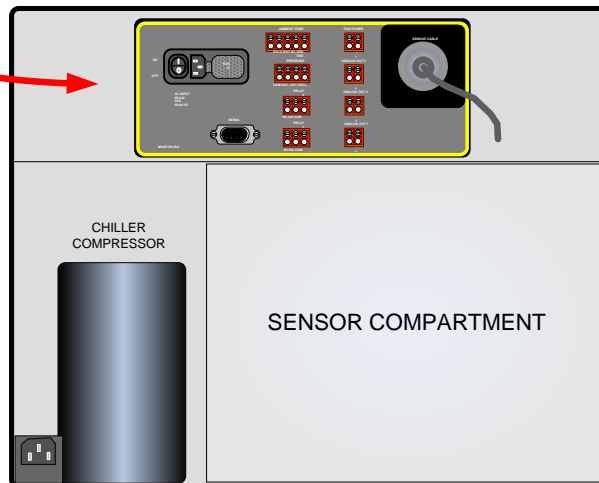
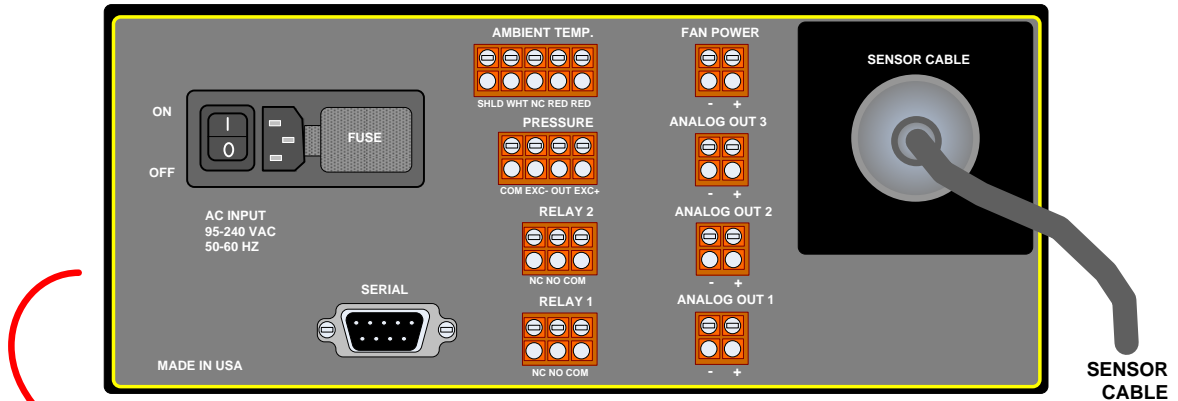

REAR VIEW
DEWTECH 390

NOTES:

Mirror Balance

The **Model CMH** incorporates an all-electronic, timed, circuit. To correct for changing “dry mirror” reflectance as a function of contamination, the mirror is heated periodically to a temperature in excess of the dewpoint, and the optical bridge output is balanced electronically for the prevailing reflectance. This heating is accomplished by reversal of the voltage across the thermoelectric cooler in the Sensor.

The ABC cycle in the Model CMH can be programmed to start at a specific time and at any interval thereafter. The cycle can also be initiated manually by a pushbutton on the front panel, or via the serial port. This feature increases the time interval between sensor and sample-line cleanings without adversely affecting overall performance.

Sensitivity to particularly troublesome impurities, such as salts and other soluble contaminants, is negligible with Edgetech Instruments Inc. chilled mirror hygrometers, because the compensation circuit and the low thermal mass of the Sensor design permit the use of a heavy condensate layer on the mirror surface without the need for a coalescence pre-cool cycle or other gimmicks to offset the servo instability, drift, and loss of accuracy often encountered in other chilled mirror hygrometers.

Programmable Functions

The ABC Cycle can be programmed to start at any specified time and repeated at programmed intervals, so that it can be programmed to operate at times when the re-standardisation will cause the least interruption of the sampling process, such as late at night or early in the morning.

Serial Port: The serial port is RS-232C compatible and can be used to output data to a terminal, printer, or computer.

The Data Output Function sends the date, time, dewpoint and alarm status to any serial device such as a computer, printer or data logger equipped with an RS-232C input. The data can be sent either on command from the external device or automatically at programmed intervals.

The Control Function allows the user to start an ABC cycle, initiate maximum cool/heat, and send the status, such as alarm condition, ABC cycle or maximum heat/cool. All commands are listed on a Help menu that can be printed or displayed on a terminal.

Analog Outputs: Two outputs, 0-5 VDC and 4-20 mA, are available simultaneously at the rear terminal connectors. These can be scaled via the front panel keypad or the serial port to correspond to any dewpoint range allowing the user to set the range to suit a particular strip chart recorder or to expand the scale for greater precision. For instance, 0V/4mA could be set to -40°C and 5V/20mA could be set to +10°C.

Alarm Relays: Two programmable relays are provided to control valves, enunciators, etc. Each alarm relay can be set independently for high or low, latching or unlatching and at any dewpoint. Alarm 1 is factory configured to operate in conjunction with the refrigerant ancillary cooler, but this function can be disconnected if not required.

Programmable Functions Continued

Isolated 4-20mA Output: An isolated 4-20mA option is available for applications requiring complete isolation between the Model CMH and the 4-20 ma output. As with the standard 4-20mA output, the range matches the 0-5V output set on the Model CMH. Maximum loop resistance is 1000 ohms.

Specifications

Dew/Frost Point Range	-90°C to +20°C
Accuracy	Dew point/Frost $\pm 0.2^{\circ}\text{C}$
Dew/Frost Point	3-wire Platinum Resistance Thermometer (PRT)
Temperature Sensor	100 ohms at 0°C, nominal
Depression	S3 Sensor - 95°C, nominal at 25°C
Auxiliary Coolant	Fan cooled, refrigerant condensing unit with temperature controller.
Sensor Materials	Nickel Chromium mirror (Rhodium available), glass, epoxy, isofoam insulation, anodised aluminium sensor body.
Depression Rate	1.7°C/second max. above 0°C
Repeatability	$\pm 0.01^{\circ}\text{C}$
Hysteresis	None
Sample Inlet Connection	¼ inch tube fitting (Swaged compression fitting)
Sample Flow Rate	0.25-2.0 liters/minute
Sample Pressure	0-70 PSIG (0-5 barg)
Operating Temperature	Control Unit 0 to 50°C
Display	LCD graphics backlit display, 0.25-in. (6.35mm) high digits
Keypad	Soft keys for setup and operation: Displayed parameter selection: °C/°F toggle: Scroll Menu to change time, date: digital averaging: baud ratio: Manual Auto Balance Cycle initiate: Program Auto Balance Cycle for start time, interval, output Track/Hold: Maximum Heat toggle: Maximum Cool toggle: View/change high and low limits for analog outputs: View/change Alarm parameters, high/low limits, high or low alarms, latched or unlatched relays.

Outputs

Track or Hold	Outputs (analog, digital, alarms) can be set to Track or Hold while in Auto Balance or Programming mode. (Factory default is HOLD)
Voltage (Standard)	0 to 5 VDC, scalable from –100 to 20°C (-148 to 68°F), 1KΩ minimum impedance
Current	<p>Active or Passive (Standard) 4 to 20 ma, scalable from –100 to 20°C (-148 to 68°F), 1KΩ max. loop resistance</p> <p>Isolated (Optional) 4 to 20 ma, scalable from –100 to 20°C (-148 to 68°F), 1KΩ max. loop resistance</p>
Digital	<p>RS-232 300/1200/2400/4800/9600/19CMH Baud N81 25-pin D-subminiature connector (female). Output of time and dew/frost point during operation. Output interval is user programmable. Programming of all keyboard functions, poll dew/frost point, output intervals, on-line Help menu.</p>
Mirror Condition (Contaminated)	Rear panel TTL output and front panel LED
Alarms	<p>Two Form C, SPDT alarm relays rated for 3 amps at 24 VDC, 120 VAC Alarm mode (high and low) programmable from keypad or RS-232 Alarm set point programmable from –99.9 to 99.9°C (-148 to 212°F) from keypad or RS-232 port. Alarms can be latched or unlatched.</p>
Auto Balance Control	<p>Manual initiation of ABC at any time Automatic ABC, start time and interval programmable from keypad or RS-232 port. Outputs programmable for Track or Hold during ABC.</p>
Dimensions	20.55 in.(522mm)W x 16.54 in.(420mm)H x 23.78in.(604mm)D
Mounting	Free standing bench-top enclosure
Power Requirements	100/115/230 VAC, ±10%, 50-60 Hz, 550 watts @ 110 VAC Connect to 15 amp mains feed breaker
Weight	88 Lbs. (40 kg)

Installation

Unpacking

Remove the **Model CMH-DM-RPC Dewpoint Hygrometer** from its carton and remove any shipping ties, clamps, and packing material (**Please Recycle Packaging**).



Heavy Item

The **CMH-DM-RPC** is a heavy instrument weighing approx. 88 Lbs. (40kg). We strongly recommend a minimum of two fit and capable people to lift the item into its permanent position. Consult your Health and Safety officer before lifting.

Note: The instrument incorporates a **refrigerant** compressor. After transport handling the **CMH-DM-RPC** must be allowed to settle before power is applied.
Place the instrument in its permanent operating position and allow a minimum of 12 hours before start-up.

Mounting, General

The standard **Model CMH-DM-RPC** is designed for bench top operation.

Place the instrument on a clean, flat surface. Ensure there are no obstructions to the free convection of air on the sides and back of the instrument.

Temperature Limits

Install the instrument in locations where the ambient temperature will be within the range 0 to 50°C.

Wiring Connections

The instrument requires a power source of 120/220 VAC (50-60Hz). When the Model CMH is received and before attaching it to a power source, examine the label indicating the proper voltage and amperage ratings and install accordingly. This unit runs at approximately 4.5 amps under normal loads. It should be connected to a 15 amp mains feeds breaker.



Safe Isolation

Switch off at the mains socket and remove the plugs before any maintenance is carried out by a qualified person. Always test components with an approved voltage meter before handling to ensure it is completely dead.

POWER SWITCHES ON THE FRONT PANEL

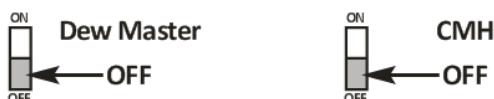

Sample Connections

A basic requirement of accurate dewpoint measurements is the proper design of the gas sampling system. In order that the Model CMH measures the actual moisture content of the gas, it is essential that the sampling components neither contribute to, nor absorb moisture from the gas. Also, the sampling components must not alter the pressure or temperature parameters of the gas such that they would affect the moisture content of the sample.

When dewpoint measurements are made, it is essential that the temperature of sampling components is not allowed to drop below the dewpoint temperature of the sample. This prevents condensation from occurring within the line, causing an in-correct measurement.

In general, the most common problem areas that affect the moisture of a sampled gas are:

1. Length of process line and sample line.
2. Leaks in the process line and sample line.
3. Adsorption or absorption of moisture in the process and sample lines due to the materials of construction. Generally, ¼" dia - 316 SS tubing is recommended; electro-polished tubing is ideal.
4. Excessive elbows, tees, valves, or other fittings used in the sample lines.
5. Back diffusion of moisture, even into a pressurized system, particularly at low dewpoints.
6. Condensation within the process line and sample line at high dewpoints.
7. Diffusion through the sampling materials.
8. Construct the shortest and safest possible route to source.

The procedures and parts recommended in this manual should be used only as a guide in selecting and designing sampling systems. If your application is of a special nature, call **Edgetech Instruments** for assistance in selecting sampling systems and components as we specialise in this area also.

Sampling Configurations

A suggested sampling system for use with the Model CMH Dewpoint Hygrometer is shown in **Figure 2-1** on the next page. A sample of the gas is brought to the hygrometer location from tapping into the process line, either by venting to atmosphere, using a suitable vacuum pump or by returning the sample to a lower pressure point in the system. The flow rate through the sample line should be sufficient to ensure continuous flushing of the lines in order to provide fast response times. Usually, a flow rate of 0.25 to 2.0 lt/min in a ¼ in. OD. line is adequate. This must be adjusted, however, to suit the length of the line, the level of absolute moisture content of the sample and the desired response time of the sample system.

Sampling Configurations – Continued

A bypass line may be used to increase the sample velocity and improve the overall response time. It is necessary that the main sample line be equipped with a valve for adjusting the sample flow rate. The hygrometer's gas sample is obtained from the pressure drop across the bypass as shown in **Figure 2-1** below. It is desirable to provide the hygrometer input with a filter, especially if the gas sample contains particulate contaminants. A sintered stainless steel filter is normally suitable Available from **Edgetech Instruments**. The filter will form a hygroscopic element that will contribute some lag to the sample system. In the design of hygrometer sample systems, minimise the number of components, such as valves, tees, and filters, upstream of the Sensor. Care should always be exercised when incorporating valves into a sample system to consider the influence of any pressure drop or back pressure on the measured value.

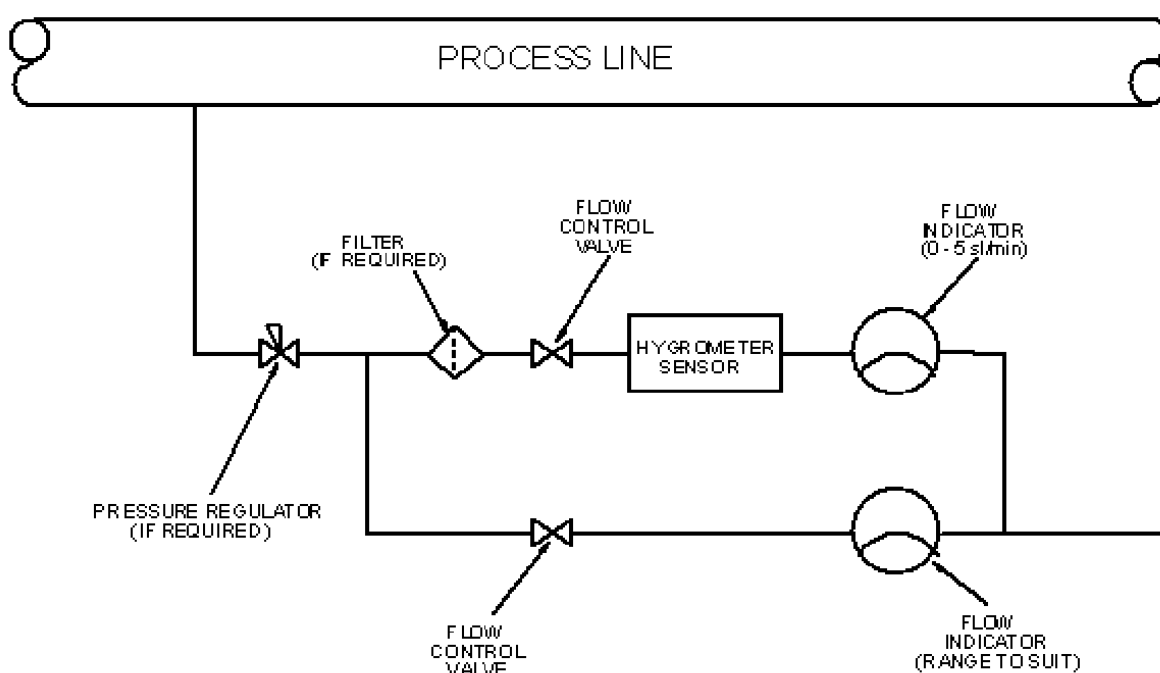

Figure 2-1. Suggested Sampling System

NOTES

Excessively high sample flow rates may cause a loss in the depression capability and unstable operation of the system.

Savings can be obtained by recognizing that the sample exhaust lines and related components need not be of as high a quality and as non-hygroscopic as those upstream of the hygrometer.

The gas to be sampled can be presented to the CMH using 1/4" OD tube and fitting on the front panel of the instrument. A sample shut-off valve may be used on the input side of the Sensor to extract the sample. Such a valve is especially useful when working with samples at high pressures and when opening the Sensor for periodic mirror cleaning.

Selection of Components At Low Dew Points

Rubber, neoprene, tygon and most plastic tubing are unsuitable for use in hygrometer systems as sample lines from the sample point to the Sensor. Non-hygroscopic tubing, such as stainless steel, Teflon, or KELL-F with a minimum of joints and fittings is recommended. The actual selection of the sample line material should be based on the degree of permanency of the installation, and the type of fittings and connections to be used. Generally, 316 stainless steel is preferred; electro-polished is ideal.

On stainless steel lines, either swage or flare-type fittings can be used. Leaks in the sampling system must be avoided, since leakage of ambient air into the sampling system will seriously offset the readings obtained.

Pressure Measurements

The dewpoint temperature of a gas is a measure of the absolute moisture content of the gas, at a given pressure, regardless of the temperature of the gas. Most conversion tables for dewpoint (or frost point) to concentration (ppm, etc.) are made at atmospheric pressure. If accurate absolute moisture content measurements are to be converted to atmospheric pressure reference values, therefore, the pressure must be known. If dewpoints are to be measured at sample operating pressures other than atmospheric, the hygrometer Sensor should be fitted with an appropriate pressure gauge

Sample Flow Rate

When setting sample flow rates at other than atmospheric pressure, or when gases other than air are involved, use **Figures 2-3** and **2-4** to convert the indicated sample flow rate reading to the actual flow rate. **Figure 2-3** gives the actual flow rate of air at pressures other than 1 atmosphere. For example, the actual flow rate of air at 30 psia is 3.3 SCFH when the sample flow rate reading is 2.3 SCFH.

Figure 2-4 gives the actual flow rate of six different gases. The actual flow rate of helium, for example, when the sample flow rate indicates 1.2 SCFH is 3.3 SCFH (at 1 atmosphere). When gas pressures other than 2 atmosphere are used, use **Figure 2-3** to convert the "actual" flow rate reading obtained from **Figure 2-4** to the true flow rate. Using 30 psia, rather than 1 atmosphere in the helium gas example above, apply the 3.3 SCFH "actual" flow rate obtained from **Figure 2-3** as the Flow Gauge Reading on **Figure 2-4**, and read 4.8 SCFH as the actual flow rate of helium at 30 psia.

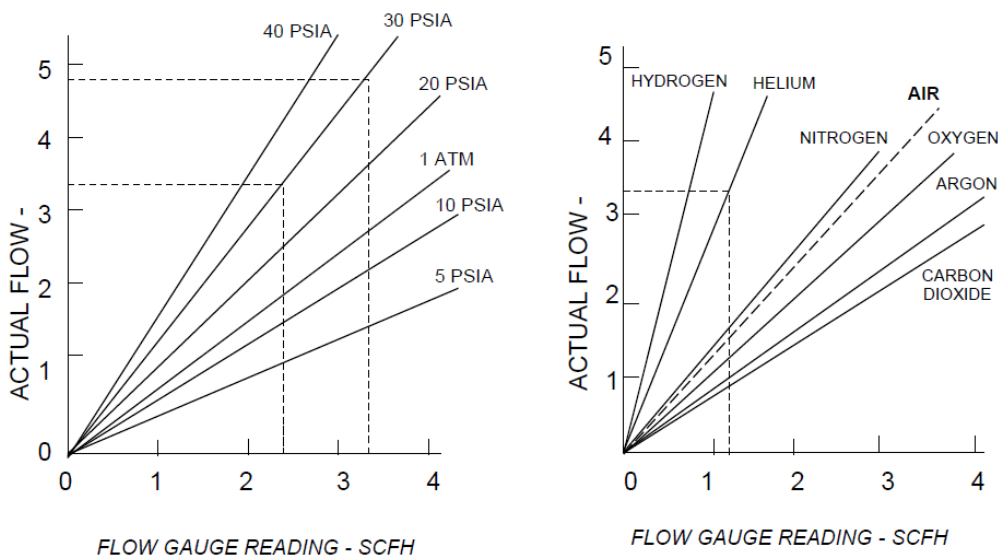

Information Display Functions

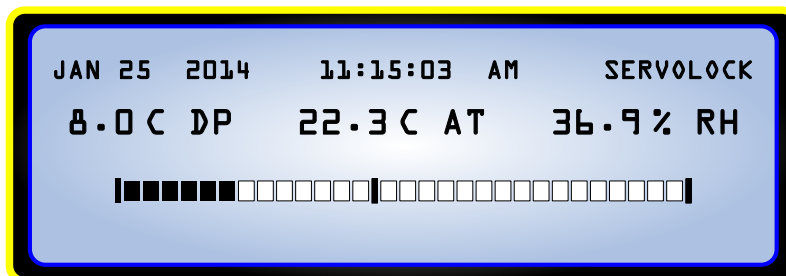

The Information Display

Information Displayed

THE LARGE LCD Display mounted on the Front Panel provides the user with all the information necessary to properly operate the **DM**. It can be used as the primary interface with the instrument, showing status of all parameters and allowing settings to be easily programmed by using the Keypad.

NOTES:

1. The RS-232 Serial Port, along with a computer or terminal may also be remotely used for programming the **DM**.
2. All programming is in non-volatile memory, so that it is retained when power is off.
3. The real time clock continues to run when power is off, maintaining the correct Time and Date information.

THE TOP ROW:

DATE	The current date
TIME	The current time
CONTROL LOOP STATUS	Shows Chilled Mirror Control Loop status

CENTER ROW (MAIN DISPLAY):

DEW POINT	The actual measured Dew Point
AIR TEMPERATURE	The actual measured Air Temperature
RELATIVE HUMIDITY	The calculated Percent RH

NOTES:

1. The three displays may be used to show any available parameter.
2. Temperature and Humidity information may be displayed in any desired sequence.

BOTTOM ROW:

BAR GRAPH DISPLAY: The Bar Graph displays an actual picture of the dew layer on the chilled mirror surface. The right hand vertical bar indicates the mirror itself, and the white bars show the actual dew layer. The layer can be seen to vary in thickness as the control loop brings the mirror into control at the dew point. Then, a thin layer of dew is maintained on the surface as the mirror temperature tracks the dew point temperature.

Operating the Dew Master

In order to operate this instrument, it is assumed that you have read the INSTALLATION section of this manual, and preliminary tasks have been done. These include:

1. The instrument has been connected to a proper AC power source.
2. If desired, the Analog Outputs, Alarm Relays, and/or Serial Digital (RS-232) Output has been wired.
3. A dew point sensor sampling system, if needed, has been installed.

Note: For dry gases, allow sufficient time for the sampling system to dry out (outgas) before taking measurements. If moisture content is only a few parts-per-million, it may be advisable to dry it out overnight.

If you have not checked these points, the INSTALLATION chapter should be reviewed before proceeding.

The Digital Display will:

1. Light up
2. Briefly indicates “DEWMASTER by EDGETECH”
3. Go into the normal display mode

Information display in detail

Time and Date

Real time information is displayed in the upper left corner of the main Information Display window. This is programmable via the keypad. It is in non-volatile memory with battery backup, so that the information will remain correct when instrument power is shut off and later turned on again.

System Status

The status of the DewMaster control systems may be seen in the upper right corner of the Display. When first turned on, it may read HEAT or STARTUP. At other times, it may read MAX HEAT, or ABC: HEAT, or ABC: STABLE, or SEEKING DP. After several minutes, the Display will read SERVOLOCK. This is the normal operating condition, which indicates that the system is tracking the Dew Point. Do not take measurements until the SERVOLOCK indication appears.

Main Displays

Across the centre of the Information Display window are the three primary displays. They may be programmed to read any measurable parameter. For example, you may wish to display Dew Point, Gas Temperature, and Pressure (with optional pressure sensor) inside your process. In addition, the sequence of these displays is independently programmable.

Bar Graph

Horizontally across the bottom of the Information Display window is the Dew Layer Bar Graph. The vertical bar on the far right of the graph indicates the actual chilled mirror within the dew point sensor. The white boxes to the left of the mirror bar indicate the thin dew layer maintained on the mirror while tracking the dew point. In other words, the bars provide a magnified picture of the mirror condition during sensor operation. Generally, the dew layer indication will take up approximately 2/3 of the bar graph.

Information display in detail – Continued

Real time information is displayed in the upper left corner of the main Information Display window. This is programmable via the keypad. It is in non-volatile memory with battery backup, so that the information will remain correct when instrument power is shut off and later turned on again.

System Status

The status of the DewMaster control systems can be seen in the upper right corner of the Display. When first turned on, it will read HEAT. At other times, it may read MAX HEAT, or ABC: HEAT, or ABC: STABLE, or SEEKING DP. After several minutes, the Display will read SERVOLOCK.

This is the normal operating condition, which indicates that the system is tracking the Dew Point. Do not take measurements until the SERVOLOCK indication appears.

Main Displays

Across the centre of the Information Display window are the three primary displays. They may be programmed to read any measurable parameter. For example, you may wish to display Dew Point, Gas Temperature, and Pressure (with optional pressure sensor) inside your process. In addition, the sequence of these displays is independently programmable.

Programming the Dew Master

Keypad Operation

The **DM** front panel keypad in **Table 3-1** has six “**soft keys**” that support the user set up and operation. The label for each key, and its function are described below.

Table 3-1. Identification of keys on front panel keypad.

Key	Function
C/F	Toggles the displayed parameters, internal parameters and RS-232 output between degrees Fahrenheit and Centigrade. Thus it is important to choose operation in C or F before any other set-up activity. Alarm values and output values are converted from Fahrenheit to Centigrade when the C/F soft key is pressed. The analog output level does not change when C/F is toggled, because ranges are converted.
MABC	Starts the Manual ABC cycle. If the DM is already in an ABC cycle, this key cancels the ABC cycle.
HEAT	Turns on/off MAX HEAT. Once this key is pressed, the sensor is kept in MAX HEAT until the MAX HEAT soft key is pressed again. In the MAX HEAT mode, SERVOLOCK is bypassed and the mirror is heated. The upper right section of the LCD flashes MAN MAX HEAT, and the RS-232 output indicates MAX HEAT. During an ABC cycle, MAX HEAT (MAX COOL) does not function. NOTE: Turning on MAX HEAT turns off MAX COOL and vice versa. Both cannot be activated simultaneously.
COOL	Turns on/off MAX COOL. The sensor is kept in MAX COOL until the MAX COOL soft key is pressed again. The upper right portion of the LCD flashes MAN MAX COOL.
ENT	Enter to the SCROLL MENU.
ESC	Exit from the SCROLL MENU.

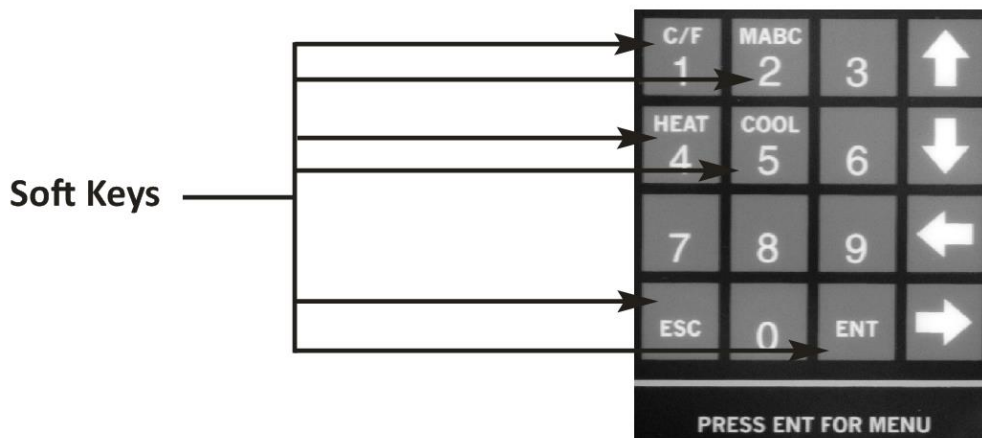

Scroll Menu (Using the Arrow Keys)

The SCROLL MENU facilitates access to DISPLAY Setup, ANALOG Setup, ALARM Setup, ABC Setup, and SERIAL Setup.

In the SCROLL MENU, use the UP, DOWN, LEFT and RIGHT arrows to make your selection and then press the ENT key. The selected function will flash on and off and can now be set to the desired value using the keypad. Pressing the ENT key will stop the flashing and another function can be selected.

Once all values have been set press the ESC key. The user will be prompted to accept all changes into non-volatile memory by pressing ENT, or reject them by pressing ESC. Either choice will return to the main DISPLAY. When entered in the SCROLL MENU, **Note that lack of activity on the keypad for 30 seconds will cause an exit to the main DISPLAY and no changes will be saved.**

Display Setup

Parameters to be viewed on the main DISPLAY: Left, Centre, or Right, can be set in any order. In the SCROLL MENU enter a display box : L, C, or R, and use the up, down arrows to choose a parameter (or select none). Then press the ENT key.

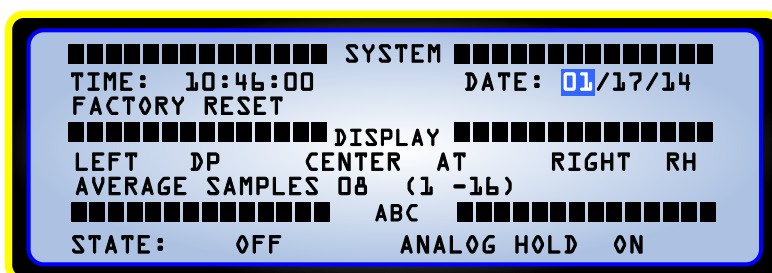

Programming the Current Date

Sample Averaging (1-16)

With Average set to 1, as each determination is made, it is shown on the display. With the Average set to 2, the two most recent determinations are added together and divided by 2, then displayed. With Average set to 16, the 16 most recent determinations are averaged together for display. If Average is set to 1, the fastest dynamic response is achieved. However, if there is some noise or artefact, it will be displayed. If Average is set to 16, since one determination is made per second, the most recent 16 seconds of data is averaged to provide each displayed value. If there is some random noise or small but irrelevant changes in dew point, setting Average to 16 will smooth out unwanted or irrelevant changes. This can help avoid false alarms.

Analog Output

Analog Output 1 is located on the rear panel. The SCROLL MENU is used to assign parameters to the analog output channel. The analog output (OUT1) is also scaled by selecting the low (LO) and high (HI) range. The output is factory set at 0-5 VDC. 4-20 ma requires a field modification. To change it, see Modifying the Analog Output in the Maintenance section.

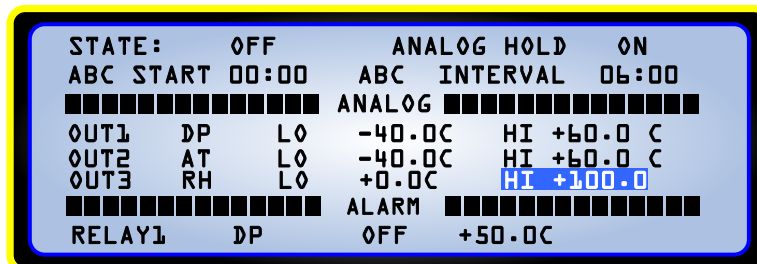

Setting the Analog Output 3 (RH) Range

ABC Cycle

The Automatic Balance Cycle (ABC) can be initiated manually at any time, or started at any specified time of day (ABC START), and repeated at regular intervals (ABC INTERVAL). The analog output can be programmed to track or HOLD the parameters during an ABC cycle and the alarm is automatically disabled. To program a periodic ABC from the SCROLL MENU the START function must be ON. If ABC HOLD is ON, the analog and serial outputs will be held at the values just prior to initiating the ABC cycle. The Display will contain the message "ABC HOLD". The hold will be released when the ABC cycle is complete and the instrument has stabilized back on the dew point.

Alarm Relay 1

From the SCROLL MENU, the relay can be programmed to be off (OFF), to activate when the low limit is reached (LOW), or to activate when the high limit is reached (HIGH).

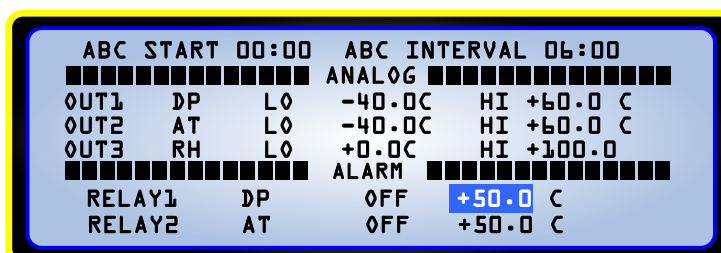

Programming the Alarm Relay 1 Set point

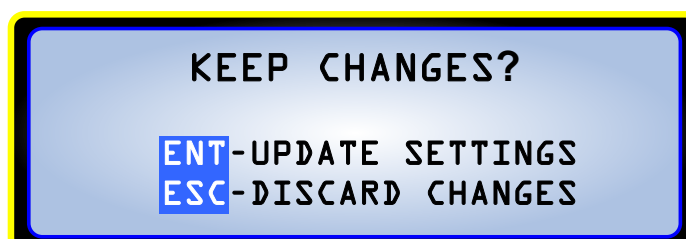

Locking In the Programming Changes

Programming the Serial Port

Serial Output

The RS232-C serial port is located on the rear panel. To access serial communication it is necessary to have the Serial Enable on (ON), from the SCROLL MENU, and also to select the appropriate baud rate. The DewMaster serial port can be used to operate the unit, program parameters, or output data to a printer, data terminal, or personal computer. For bi-directional communications (such as with a PC or Terminal), a communication or terminal emulation software package is needed on the PC. There are many inexpensive communication programs readily available. Two such programs are HyperTerminal in Windows or PROCOMM PLUS by Quarterdeck/Datastorm Corp.

External Device Connection

Connect an RS-232 cable between the DewMaster 9-pin female D-Type connector and the RS-232 serial port of the external device. All hardware handshaking lines are available at the connector; however a 3-wire XON/XOFF cable is all that is normally required. The serial port is wired as a DTE device (Data Terminal Equipment); i.e., Transmit (TXD) is pin 2 and Receive (RXD) is pin 3. Circuit common is pin 5. For connection to a DCE device (Data Communications Equipment) such as a PC, a direct pin-to-pin cable can be used. For connection to another DTE device such as a printer, a null modem adapter is required.

PC or Terminal Setup

Set the DewMaster to the preferred baud rate via the SCROLL MENU. The available baud rates are 19.2K, 9600, 4800, 2400, and 1200. For optimum performance, the baud rate should be set to the highest rate that the connected device can accommodate reliably. Set up the PC's communication program for a baud rate to match the DewMaster. The protocol should be 8 data bits, 1 stop bit, and no parity (N81).

RS-232 Commands and Parameter Setting

General

Several of the setup and operating features of the DewMaster are available via the serial port. Commands can be upper or lower case. When any key is pressed, the DewMaster will respond with "Input: " and the key that was pressed "key". If the command is a single key command, pressing ENTER will initiate the command. For a two key command, press the second letter and then the ENTER key to initiate the command.

Help Menu

Once communication has been established, the available commands can be viewed by accessing the HELP menu.

Type the letter "H". The display will reply with INPUT: H. Press ENTER and the HELP menu as shown in Table 12-1 will be displayed on the screen.

Help Menu Table

Commands	Examples (Max Entries Shown)
Start a Manual ABC Cycle	AB <CR>
ABC enable toggle	AE <CR>
ABC Start Time (HH:MM)	AS <CR> 23:59 <CR>
Analog Hold Toggle (on/off)	AH <CR>
ABC Interval (HH:MM)	AI <CR> 23:59 <CR>
Alarm 1 (> or <) (Deg) (param)	AL1 <CR> > 100.0 7<CR>
Alarm 2 (> or <) (Deg) (param)	AL2 <CR> < -100.0 7<CR>
Analog 1 Output (Min) (Max) (param)	AO1 <CR> -100 100 7<CR>
Analog 2 Output (Min) (Max) (param)	AO2 <CR> -100 100 7<CR>
Analog 3 Output (Min) (Max) (param)	AO3 <CR> -100 100 7<CR>
Average (Number of Data Points)	AV <CR> 16 <CR>
Enter New Date (MM/DD/YY)	D <CR> 12/31/99 <CR>
Latch Alarm1 Toggle ON/OFF	L1 <CR>
Latch Alarm2 Toggle ON/OFF	L2 <CR>
Max Heat Toggle ON/OFF	MH <CR>
Max Cool Toggle ON/OFF	MC <CR>
Output Interval RS232 (Secs)	O <CR> 3600 <CR>
Poll for Parameters	P <CR>
Display a Status Report	ST <CR>
Enter New Time (HH:MM:SS)	T <CR> 23:59:59 <CR>
Temperature Units (F, C)	U <CR> C <CR>

Press ENTER to continue.....

Notes:

When a 'param'(parameter) entry is required, each parameter has a numeric value as follows: DP (Dew Point) = 1; AT (Ambient Temperature) = 2; RH (Relative Humidity) = 3; PPMV = 4; Gr/lb = 5; PSIA = 6; PSIG = 7 and Wet Bulb = 8.

Whenever a setting is changed via the serial port, the serial output times are recalculated. Input characters are not case sensitive.

Start an ABC Cycle

This command initiates an ABC cycle at any time. The cycle is the same as a programmed ABC cycle. Type the letters "AB" and press the ENTER key.

ABC Enable

Type "AE" and then ENTER to alternately enable or disable the timed ABC function. The start time and interval settings will not be changed.

NOTE: Two digits must be used for each entry field.

ABC Start Time

Type the letters “AS” and press the ENTER key. Enter the time “Hours: Minutes” in 24 hr. format, and press the ENTER key.

Examples: “02:00”, is 2:00 AM: “14:30” is 2:30 PM.

ABC Internal

Type the letters “AI” and press the ENTER key. Type the time in “Hours:Minutes” and press the ENTER key.

Example: If the ABC Start Time is 08:00 o’clock in the morning and the ABC Interval is 02:00, the first ABC cycle for the day would occur at 8:00 AM and every two hours thereafter.

ABC Analog Hold

Typing the letters ‘AH’ will toggle the ABC Hold feature on or off. If ABC Hold is on, the analog and serial outputs will be held at the values just prior to initiating the ABC Cycle. The serial output will contain the message “ABC Hold”. The hold will be released when the ABC Cycle is complete and the instrument has stabilized back on the dew point.

ALARM 1 AND (OPTIONAL) ALARM 2

The alarm relays can be set to operate at predetermined parameter limits.

Each relay can be set as a high or low set point by use of the greater than “>” and less than “<” symbols.

Each relay can also be independently set to latch when the preset limit is exceeded. In the latch mode, the alarm will remain active even if the alarm condition returns to normal. To reset a latched alarm relay, press the “SETUP” key twice from the main screen. If the latch mode is not set, the relays will deactivate when the alarm condition is corrected. The front panel alarm indicators will flash to alert the operator of an alarm that has occurred.

To enter or change the alarm limits, type the letters “AL1” for alarm 1 or “AL2” for alarm 2 and press ENTER.

Enter the set point beginning with the > or < symbol followed by a space and the sign and value of the alarm limit, and the parameter number of the variable. When completed, press the ENTER key.

Examples:

> +22.3 1 sets relay number one to activate at a level greater than +22.3 degrees dew point (param 1).

< 25.0 3 sets relay number two to activate if RH (param 3) falls below 25%.

Alarm 1 and Alarm 2 Latches

The alarms can be set to latch on an alarm condition by typing "L1" for alarm 1 or "L2" for alarm 2. A latched alarm will not reset itself when the alarm condition is resolved but requires operator intervention to reset.

The L1 and L2 commands toggle the latch on or off. To reset a latched alarm, press the 'SETUP' key twice.

Number of Data Samples to Average

This command sets the number of data samples to average. Data is sampled once per second. Therefore, a number of 4 would display a 'rolling average' for the last 4 seconds. The limits are 1 to 16 samples.

Type the letters "AV" and press the ENTER key. The DewMaster will respond with "Enter SETTING =." Type the two-digit value and press the ENTER key.

Analog Output (Low) (High) (Param)

This function sets the 0-5 volt or 4-20 ma (analog) lower and upper output ranges and the parameter for each of three output channels. The instrument range is 100 to +100°C (-148 to +212°F).

A plus (+) sign is not needed for positive temperature entries, but a minus (-) sign is necessary.

Type the letters "AO1" for channel one, "AO2" for channel two, or "AO3" for channel three, and press the ENTER key. Enter the limits with a minus sign first (if negative), then the lower limit, a space, the positive or negative upper limit, a space, and the parameter number.

Press the ENTER key to record these values.

Example:

Entering "-33 45 2" sets a low value of -33°, a high value of +45°, and a parameter of Ambient

Temperature (2). The units, C or F, will be whichever is active at the time of the setting. If the units are changed later, all affected parameters will be set to the new units.

Setting the Date

Type the letter "D" and then press ENTER.

The DATE format is: MONTH/DAY/YEAR

"01/01/00" = January 1, 2000

"12/31/99" = December 31, 1999

NOTE: Two digits must be used for each entry field and separated by a backslash character.

Output Interval

This is the interval in seconds between automatic data output transmissions of the serial data output. The time range is from 0 to 3600 seconds. Type the letter "O" and press the ENTER key. Enter the desired interval in seconds and press ENTER.

Poll for Output

This command requests the DewMaster to send serial data at any time and is independent of the automatic interval.

Type the letter “P” and press the “ENTER” key.

Manual Heat

This command toggles the Sensor’s heater on or off. It can be initiated at any time and can be used to clear excessive moisture from the mirror in flooding situations.

Type the letters “MH” and press the ENTER key. The DewMaster will display a flashing MAN MAX HEAT and the temperature will rise. To turn off the MANUAL HEAT mode, enter “MH” again.

Manual Cool

This command toggles the Sensor’s cooler on or off. It can be used to test the maximum depression of the Sensor.

Type the letters “MC” and press the ENTER key. The DewMaster will display a flashing MAN MAX COOL and the temperature will decrease. To turn off the MANUAL COOL mode, enter “MC” again.

NOTE: After an extended period of time in the cool mode, excess moisture or frost will form on the mirror. It may be necessary to “Manually Heat” the mirror to shorten the drying time.

Time

Type the letter “T” and press ENTER.

The time format is: Hours:Minutes:Seconds. Hours is expressed in 24-hour military time.

Enter the desired time with colon delimiters:

Examples:

“00:00:00” = 12 midnight

“23:59:59” = 11:59:59 pm

Units (F,C)

The DewMaster can display temperature in either Degrees C or Degrees F. The display and RS-232 data will reflect the selection.

Type the letter “U” and press ENTER. Type “C” or “F” and press ENTER.

Status Report

This command gives the user a report of all of the current settings. To get a status report, do the following.

Type the letters “ST”. The display will show: Input: ST

Press the ENTER key. The following sample status report will display.

DewMaster System Status Report

ABC data:	State	StartTime	Interval	Hold
	ENABLED	0:00:00	2:00	OFF

ALARM data:	#	Item	Type	Value	Latch	State
	1	DP	HIGH	0.00 C	ON	READY
	2	AT	LOW	-5.00 C	OFF	ACTIVATED

ANALOG data:	#	Item	Low	High
	1	DP	-20.00 C	40.00 C
	2	DP	-40.00 C	60.00 C
	3	RH	25 %	75 %

DISPLAY data:	Left	Middle	Right	Average
	DP	PPMV	GR	4

SERIAL data:	Baud	Interval	State
	9600	1:00	ON

Press ENTER to continue or ESC to return to normal operation.

Help Menu Table.

Options	Example (Max Entries Shown)	
Display the HELP Menu	H	<CR>
Enter New Time (HH:MM:SS)	T	<CR> 23:59:59
Enter New Date (MM:DD:YY)	D	<CR> 12:31:99
Temperature Unit (F,C)	U	<CR> C <CR>
ABC Start Time (HH:MM)	AS	<CR> 23:59 <CR>
ABC Interval (HH:MM)	AI	<CR> 23:59 <CR>
Alarm 1 (>,<) (+) (Deg)	A1	<CR> < 100.0 <CR>
Alarm 2 (>,<) (+) (Deg)	A1	<CR> < -100.0 <CR>
Analog Output (min) (Max)	A0	<CR> -100 100 <CR>
Baud Rate (Baud)	B	<CR> 19200 <CR>
Output Interval RS-232 (Sec Gap)	O	<CR> 3600 <CR>
Poll for Dew Point	P	<CR>
Start a Manual ABC Cycle	AB	<CR>
Average (Number of Data Points)	AV	<CR> 16 <CR>
Max Heat Toggle ON/OFF	MH	<CR>
Max Cool Toggle ON/OFF	MC	<CR>
Latch Alarm1 Toggle ON/OFF	L1	
Latch Alarm2 Toggle ON/OFF	L2	

Baud Rate

The available baud rates in the CMH are: 19200, 9600, 4800, 2400, 1200, or 300

NOTE: Both the Model CMH and the computer must be set to the same baud rate for communication to take place. If the unit is not communicating properly, check the CMH baud rate setting via the front panel and set the communications software to match the CMH. Also verify that the data format is correct (i.e., Data Bits = 8, Stop Bits = 1, Parity Bit = N).

RS-232 Output Interval

This is the interval in seconds between automatic data output transmissions of the RS-232 data output. The time range is from 0 to 36000 seconds.

NOTE: An entry of zero will stop the output of RS-232 data.

Press the ENTER key on the computer keyboard. The “Enter Command (H for Help):” prompt is displayed. Type the letter “O” and press the ENTER key. Enter the desired interval in seconds and press ENTER.

Default Programmable Parameters

If a fault is detected in the parameter memory, or if the non-volatile memory chip is replaced, the instrument will replace all of the user entered parameters with the default parameters listed in Table 3-5.

Table 3-5. Default Programmable Parameters.

Function	Default Parameters
ABC ST	08 00 (HOURS MINUTES)
ABC INT	12 00 (HOURS MINUTES)
OUT HIGH	+60 DEGREES C
OUT LOW	-40 DEGREES C
ALARM 1	>+50.0 DEGREES C
ALARM 2	>+50.0 DEGREES C
AVE	01
BAUD	2400
OUT INT	60

System Operation

Main Control Loop (General Description)

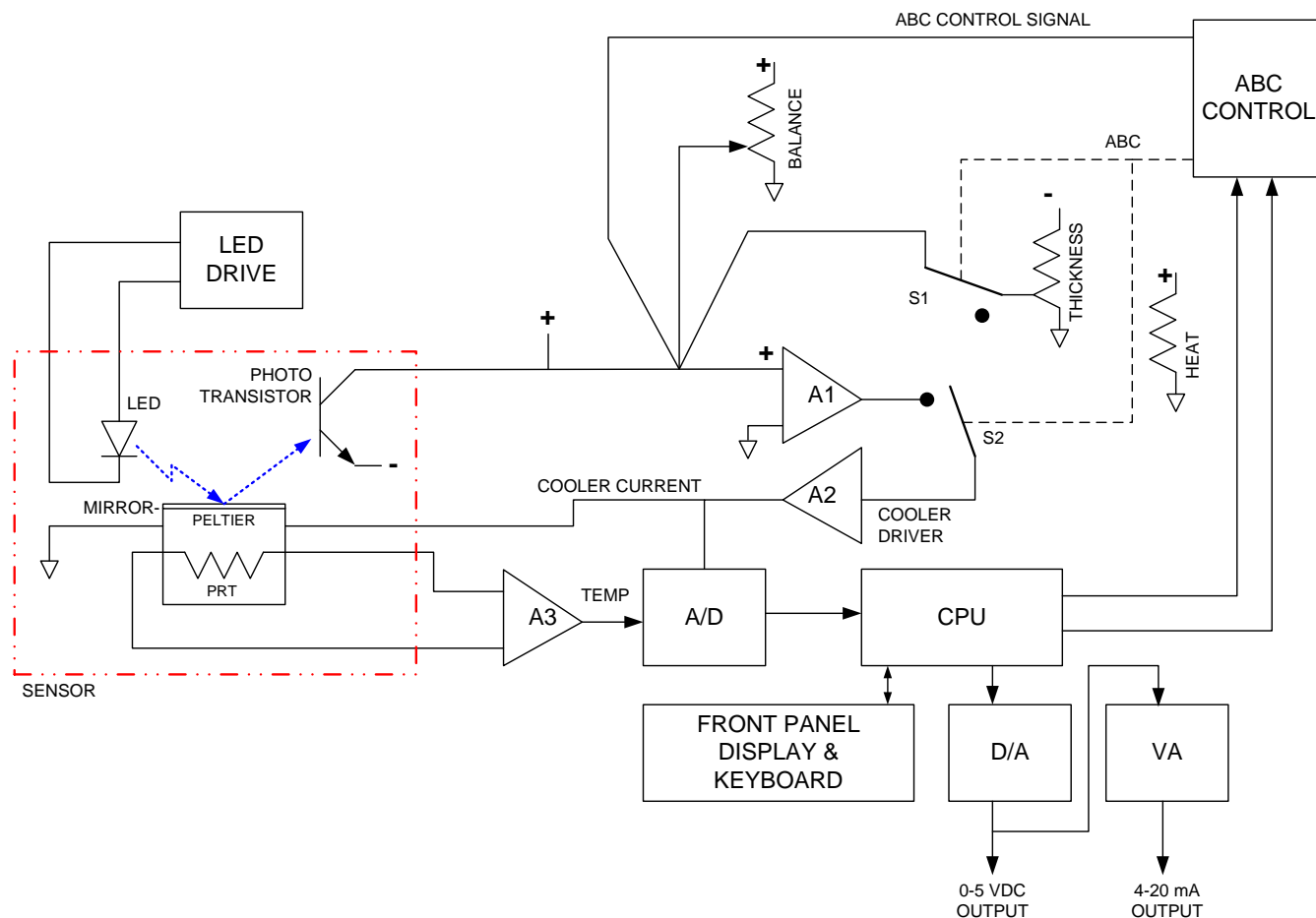

System Operation – Continued

The Model CMH Dewpoint Hygrometer accurately measures the dewpoint of a gas by cooling a mirrored surface, over which the gas flows until a layer of dew forms on the surface.

When the mirror is dry (no dew/frost), amplifier A1 outputs a positive voltage and A2 a positive current into the peltier device to cool the mirror surface.

As dew forms on the mirrored surface the light reflectance is decreased, resulting in reduction in voltage from amplifier A1 (possibly becoming negative) causing a reversal of current to the peltier device and the mirror surface to heat.

The surface of the mirror is maintained at a temperature to control a uniform layer of dew/frost. That temperature is the dewpoint.

Temperature

The PRT is a component in a bridge, the output of which, proportional to the temperature of the mirror surface, is amplified by A3 and converted into a digital value, approximately once per second, which is used for display of the dewpoint temperature, analogue output (via a digital-to-analogue converter), monitoring of alarm levels, and RS-232 digital outputs.

Automatic Mirror Balance Control (ABC)

At programmable intervals, the Model CMH can be forced into an Automatic Balance Control (ABC) cycle to compensate for any build-up of contaminants on the mirror surface, which may change the optical balance of the system. When an ABC is begun, the control loop is interrupted, the mirror is heated thus evaporating the dew, and the new balance point is found that compensates for contaminants that may have accumulated and caused a change in the reflectance of the mirror. The control loop is then reconnected, and, after some time, normal control operation is re-established.

Microprocessor Control

All timing functions, such as time and frequency of ABC cycles, parameter settings, such as alarm levels, and outputs, both analogue and RS-232, are microprocessor controlled. All parameters can be viewed and/or changed via both the front panel keypad and the RS-232 port. The keyboard menu system is arranged for ease of use. All functions can be accessed by no more than four key presses, some by two. When a key is pressed, the microprocessor stops its normal routine of temperature measurement to service the user. Normal operation is resumed when the task is completed, or when about 10 seconds passes without a key being pressed. When using the RS-232 port to communicate with the Model CMH normal operation is interrupted.

Circuit Descriptions

Thermoelectric Dewpoint Temperature Control Circuit

The thermoelectric dewpoint temperature control circuit heats and cools the mirror surface of the dewpoint sensor to the temperature at which a layer of dew on the mirror is in equilibrium with the moisture in the sample gas in the Sensor. It maintains that equilibrium, even though the temperature necessary to do so may vary. To do this, an LED light source shining on the mirror surface of the Sensor is driven from a constant current source. This circuit maintains the LED current constant, regardless of changes in cable resistance, cable length, temperature, etc. The light reflected from the mirror surface in the Sensor is detected by a phototransistor. If the mirror surface is dry, the Control Amplifier circuit calls for cooling of the mirror surface. When too much dew forms on the mirror surface the cooling level is reduced to heat the mirror surface, if necessary. These circuits, i.e., the phototransistor sensing the reflectivity of the Sensor mirror surface, the Control Amplifier circuit, and the Cool/Heat Amplifier, are connected to form a servo-controlled loop. When operating, this loop adjusts itself automatically to control the Sensor mirror surface at that temperature required to maintain a layer of dew on the mirror surface in equilibrium with the gas sample in contact with it.

When the Model CMH is in the Automatic Mirror Balance Control (ABC) cycle mode, the servo loop described above is interrupted, the Cool/Heat Amplifier is forced to heat the mirror surface to evaporate any dew or frost present, and the circuitry automatically compensates for any changes in mirror reflectivity. Once this compensation has been achieved, the loop is re-established to control on the dewpoint temperature as before.

Sensor PRT Resistance-to-Voltage Converter

The temperature of the mirror surface is measured by means of a Platinum Resistance Thermometer (PRT) embedded beneath the mirror surface. The resistance of the PRT device varies almost linearly with changes in temperature. This circuit interfaces with the PRT and includes adjustments for ZERO, SPAN, and LINEARITY.

Automatic Mirror Balance Control Circuits

The Model CMH automatically verifies its own performance on a timed sequential basis by means of an automatic self-standardization circuit. This circuit adjusts for changes in the condition of the mirror surface, or for changes in any of the circuitry associated with the Sensor optical system and control loop. The Automatic Mirror Balance Control (ABC) cycle is initiated when the instrument is switched on, and can also be initiated automatically at programmable intervals.

An ABC cycle may also be initiated manually at any time by depressing the MBAL (Manual Automatic Balance Control) key on the Control Unit front panel keypad, or remotely via the RS-232 port.

Automatic Mirror Balance Control Circuits – Continued

The duration of the heating period is pre-programme. At low temperatures more time is needed to evaporate the condensate. If the temperature at the beginning of the ABC cycle is greater than 0°C, the mirror is heated for 1 minute, between 0°C and –25°C, 2 minutes and below –25°C the heating period is 4 minutes. At the end of the heating period the circuit automatically balances the optical bridge and control loop and returns to normal operation.

Alarm Set

With the Model CMH Control Unit, it is possible to establish set points for operation of each of two alarm relays. Once the set point has been established, between –100 and 100°C, the alarm relay remains de-energised as long as the actual dewpoint does not satisfy the alarm set point, and energises as soon as the actual dewpoint satisfies the alarm set point. The outputs of each relay [a Single Pole, Double Throw (SPDT) contact] are all brought to the rear panel connector for use in customer provided alarm indicator circuits.

Display

The Model CMH is equipped with an 8-character alphanumeric LED display allowing presentation of numeric and alphanumeric information.

Track or Hold Circuit

When the system is controlling on the actual dewpoint temperature the Track or Hold circuit provides an analogue dewpoint temperature output identical to the direct dewpoint temperature output, the Track mode. During an ABC cycle it gives a steady output corresponding to the actual dewpoint value when the ABC cycle was initiated, the Hold mode. Using the output of the Track or Hold circuit, rather than the direct output of the Sensor mirror PRT, means that any process control operations can be isolated from the effects of the rise and fall of the mirror temperature during the ABC cycle. This feature can be disabled by turning HOLD off.

During the initial ABC cycle when the Model CMH is switched on, the output of the Track or Hold circuit will be the ambient temperature.

Routine Maintenance

To ensure accurate and reliable operation of the Model CMH, a periodic maintenance programme should be established.

A regular visual check should be made to ensure that nothing has been placed near or around the instrument that may impede the normal flow of air by natural convection around the instrument or that initiated by the fans within the auxiliary cooling unit.

Mirror Cleaning Schedule

Contrary to what might be expected, the mirror surface in the Sensor need not be spotless for proper operation. In fact, mirror surface contaminants can act as nuclei for the condensate, thus hastening dew formation.

The build-up of contamination on the mirror surface normally occurs very slowly. Dust and other matter borne by the sample gas adhere to the mirror surface, reducing the reflectivity the mirror surface. This is the same effect caused by the presence of dew on the mirror. It is necessary occasionally, therefore, to compensate for the change in reflectivity of the mirror surface due to contaminants.

This can be done automatically in the Model CMH with each Automatic Balance Control (ABC) cycle. This feature adjusts automatically for any reduction in mirror surface reflectivity that occurs when the mirror is dry, and ensures that normal operation of the Model CMH will be proper, even after long periods of continuous unattended operation.

Eventually, however, build-up of contaminants on the Sensor mirror surface may make it necessary to clean the mirror surface. The interval between routine mirror cleaning can normally be expected to be 90 days. If, however, operating conditions are particularly severe, more frequent mirror cleaning may be required. Whenever the instrument cannot electronically adjust for contamination, the ABC cycle cannot be completed. This is indicated by the illumination of the CLEAN MIRROR LED. When this occurs, clean the mirror surface and other optical parts. After cleaning the mirror press the MBAL key on the Model CMH front panel to allow the instrument to readjust for the clean mirror surface before returning to normal operation.

Mirror Cleaning

To clean the mirror surface remove the spin-off cover from the Sensor to expose the mirror.



Caution

When operating with a pressurised sampling system, be sure to remove pressure from the Sensor prior to removing the Sensor cover.

When the cover has been removed, lightly dampen a cotton bud with isopropyl alcohol. Cotton buds and cleaner are provided in the Cleaning Kit shipped with the Model CMH. Do not use an excessive amount of cleaner on the cotton bud. Shake the cotton bud to remove excess fluid prior to cleaning the mirror surface.

Mirror Cleaning – Continued

After cleaning the mirror surface, remove all traces of the cleaning fluid with the dry end of the cotton bud. To remove particulate matter present around the mirror surface, use a clean, dry cotton bud, not isopropyl alcohol.

If isopropyl alcohol is ineffective in removing hard deposits or varnishes, a fine polishing paste may be used sparingly. To prevent excessive eroding of the mirror surface, avoid using this material unless absolutely necessary.

Calibration of PRT

A Platinum Resistance Thermometer (PRT) is used in the dewpoint Sensor. To measure the temperature, the PRT resistance is converted to a voltage by a PRT amplifier. This amplifier has controls for ZERO, SPAN, and LINEARITY. These are factory set to give a linear output voltage proportional to the temperature sensed by the PRT and normally do not have to be changed. If there are changes in the length of cable used to mount the dewpoint Sensor remotely, however, they may require readjustment (there is approximately a 0.1°C change in output for a 50-foot change in cable length). Factory adjustments are made based on cable lengths specified at time of purchase. If it becomes necessary to check the operations of the PRT amplifier, or if the remote cable length is changed significantly after shipment, then the procedures described below should be followed. A precision calibrated resistance decade box with an accuracy of $\pm 0.01\%$ is required for making these adjustments.

Calibration of the PRT amplifier

When recalibration is attempted for the reasons discussed above, the following procedure is recommended:

1. Remove the Sensor from the end of the cable and prepare a precision resistance decade box to be used to simulate the PRT in the Sensor.
2. Turn on power to the Model CMH and wait $\frac{1}{2}$ hour to ensure that all electronics have reached equilibrium.
3. Remove the internal top cover by removing the six retaining screws.
4. Set the resistance decade box to 100.00 ohms.
5. Use three equal length and gauge wires to connect pins 4 and 10 of the connector removed from the Sensor to each other and to one terminal of the decade box. Connect the other terminal of the decade box to pin 9 of the Sensor cable connector.
6. The front panel digital meter should now read 00.0°C. Adjust the ZERO potentiometer, R76, on the Main Board until this reading is obtained.
7. Set the resistance decade box to 119.40 ohms and adjust the SPAN potentiometer, R69, on the Main Board to give a display of 50.0°C.
8. Set the resistance decade box to 134.70 ohms and adjust the LIN (Linearity) potentiometer, R83, on the Main Board to give a display of 90.0°C.

9. Repeat steps 6, 7, and 8 as often as required to bring each reading to within $\pm 0.1^{\circ}\text{C}$ of the values given. Each adjustment interacts slightly with the others so it may be necessary to repeat these steps several times.
10. By setting the resistance decade box to 88.22 ohms, a lower value of -30°C can be checked.
11. Once calibration has been completed, remove the resistance decade box and reattach the Sensor to the cable. After the Sensor is reconnected, press the MABC key and replace the Control Unit cover. The resistor values to be used for calibration purposes (listed in the above procedure) are nominal values that serve for most Model CMH sensors. This allows for interchangeability of Sensors without recalibration. If, however, the calibration values for a particular Sensor differ from those listed here, the correct values will be included on a separate document shipped with the Sensor and the certificate of calibration.

Operating Adjustments

The Model CMH is designed to operate with minimal operator control. Although there are several potentiometers on the PC boards, all are factory set, and it is not normally necessary to adjust them. The user may, however, make certain adjustments after knowledge of the instrument and its capabilities has been achieved, and when familiarity with the instrument has been gained. These adjustments are BALANCE, THICKNESS, GAIN, and COMPENSATION. The BALANCE adjustment affects the static set-up of the instrument, and the other three affect the dynamic response of the instrument to changes in the dewpoint temperature of the sample.

Optical Adjustment Procedure

1. Clean the mirror as described previously.
2. Remove the cover from the instrument chassis.
3. Connect the negative (-) lead of a Digital Volt Meter to TPAGND
4. Connect the positive (+) lead of the DVM to TP12
5. Press MBAL button on front panel.
6. Adjust R64 (Thickness) to give 6VDC ($\pm 0.1\text{VDC}$).
7. Remove test leads.
8. Press MBAL button.
9. Adjust R47 to give between 3 to 5 LEDs illuminated on the CONTROL meter

NOTE: The above adjustments must be made with the unit in ABC mode with the Mirror Balance LED on steady, NOT flashing.

Gain

GAIN control potentiometer R57 is a single-turn control similar to the THICKNESS control. The GAIN control adjusts the overall gain of the Model CMH control loop that controls the proper dewpoint temperature. The overall gain of the control loop is dependent on the electric gain of the control loop circuitry, and the gain of the condensation phenomenon on the dewpoint Sensor mirror surface. The gain of the condensation phenomenon is related to the mobility of the condensate, which is both a function of the absolute temperature and the state of the condensate (water or ice), being high for high temperatures and water deposits, and low for low temperatures and ice deposits. The GAIN adjustment compensates for this change in gain of the condensate phenomenon.

Gain – Continued

The GAIN control is set at the factory to give stable operation over the range of operation of the instrument. Before making adjustments to the GAIN control, always record the factory-set position to aid in returning to the original position at a later date. If, however, dynamic performance must be optimised for a particular operating dewpoint, the GAIN control may be adjusted clockwise as far as possible until unstable operation is experienced, as indicated by oscillation of the dewpoint temperature and the operation of the CONTROL indicator. When oscillation occurs during this adjustment, slowly turn the control anticlockwise until stable operation is established at a higher gain setting.

Before returning to normal operation, press the MBAL key on the front panel of the Model CMH to instigate an ABC cycle.

Compensation

COMPENSATION control potentiometer R88 introduces phase lead into the amplifier circuit to compensate for the thermal phase lag characteristics of the thermoelectric cooler in the dewpoint Sensor. Introduction of this phase lead into the optical system and mirror temperature control loop permits the loop to operate at a higher gain setting without oscillation, resulting in improved dynamic performance. The frequency response of this compensation network is such that it is effective only at dewpoints of 0°C and above.

The COMPENSATION control is set at the factory for optimum dynamic response when operating at high dewpoints and should not need to be adjusted. Before making adjustments to the COMPENSATION control, always record the factory-set position to aid in returning to the original position at a later date. Proper adjustment of the COMPENSATION control may be achieved, however, by introducing a gas sample into the Sensor at the highest dewpoint anticipated. With the instrument operating normally on this dewpoint, rotate the COMPENSATION control fully anticlockwise and advance the GAIN control until a steady oscillation is obtained. If oscillation occurs, rotate the COMPENSATION control clockwise slowly, noting the change in response for each increment of change until the oscillation ceases. If no oscillation occurs, it is possible to operate at maximum GAIN.

Wetted Parts

Since the Sensor comes into contact with the sample gas, it might be important to know the materials of construction of the wetted parts. The wetted parts include:

- Rigid polyurethane isofoam (closed cell) securing mirror
- Plastic Mylar foam protector
- Silicon rubber adhesive (RTV)
- Glass plate optics protector
- Stainless steel compression fittings with PTFE tape

Suggested Spares

We recommend that instruments be returned to the factory for repairs or replacement of parts. Some users may, however, be capable of making repairs in the field. In these cases, spare parts that may be needed in infrequent circumstances may include.

Part Number Description

C9057-0007	Front PCB with switch matrix
C9057-00038	Rear PCB
D9057-00036	Main PCB
A31966	EPROM, customized
CMH-S3	S3 Sensor, 3-stage, 95°C depression
D16118-16	Cleaning kit with fuses
C24359	Ambient Temperature PCB, Model CMH-2 only
B24461	Ambient Temperature probe, Model CMH-2 only

Trouble Shooting

In some cases of faulty instrument operation, the source of trouble will be immediately apparent. In others, this will not be the case, since a given symptom may often be due to any one of several causes. In locating and eliminating such faults, two methods are recommended:

1. If trouble arises, a number of simple preliminary checks, listed in Table 6-1, should be made before proceeding with more elaborate tests. These checks, which can be performed without disturbing any components of the system, are designed to detect or correct those troubles most likely to occur.

Symptom	Corrective Action
Instrument is completely inoperative with no LEDs lit.	Check the 120/240 volt PC card for proper position for the input AC voltage being used. If the fuse is good, check for line voltage across the AC terminals.
Line voltage and fuses are good, but still no indication of equipment operation.	Unplug the power lead and slide the clear plastic door to the left to check the AC voltage select card and fuse. Check that the cables connecting to the PCB are intact.
Replaced fuse blows when power is turned on again.	Check that the proper fuse is being used. The fuse value should have a 2-amp rating for 120 VAC operation and a 1-amp rating for 240 VAC operation. Fuses should be rated 250V, 3 AG, Slo-Blo.

Trouble Shooting - Continued

Symptom	Corrective Action
CONTROL indicator is too far left or too far right during the time the ABC indicator is on steady.	This indication can occur if the Sensor is not plugged in, if the Sensor has been changed, or if the Sensor mirror surface is very dirty. If the sensor has been changed, adjustment of BALANCE potentiometer R52 can usually bring the indication back to centre scale. A dirty mirror causes the CONTROL indicator to indicate more to the left, cleaning the Sensor mirror should bring the indication back to the centre.
Control indicator and dewpoint temperature output do not settle to a steady reading.	Check that the gas sample flowing through the Sensor is at a constant pressure and not fluctuating, and that there are no leaks in the sample system. Assuming there is no problem with the sample, then either the GAIN or COMPENSATION control may be set too high, or the sample flow rate may be too high.
Sluggish response to changes in dewpoint.	The THICKNESS setting may be too high or the GAIN setting may be too low.
Dew point reading is always too high.	The THICKNESS setting is too low or the GAIN setting is too low.
When operating at temperatures near 100°C, the instrument indicates ambient temperature rather than dewpoint temperature.	If the Sensor base temperature has been allowed to exceed 105°C, the thermostat in the Sensor will open, preventing the mirror from cooling to the dewpoint. The mirror temperature will now rise to ambient. Reduce the Sensor temperature to 80°C or below to reset the Sensor thermostat.

Table 6-1. Troubleshooting chart: preliminary checks.

2. If the trouble is not located or remedied by the preliminary checks, a series of tests, described in Table 6-2, can be used to isolate the fault to one of the major sections of the system. When this is done, the faulty section can then be replaced or checked systematically to locate the particular component causing trouble.

Symptom	Recommended checks and replacement
<p>Not all three power supply voltages, +5V, +15V, and –15V, are present.</p>	<p>This is probably caused by a failure in one of the power supplies or a poor cable connection from the transformer to the main PCB (connector J2). It can also be caused by an overload on one of the power supply regulator circuits. Turn the equipment off for a few minutes and then turn it back on. The overload protection circuits on the power supplies will reset and, if the overload was temporary, the fault will clear.</p>
<p>Sensor mirror does not heat above ambient temperature during an ABC cycle, but operates on dewpoint readings.</p>	<p>Measure the voltage at TP2 during the Automatic Balance Control (ABC) cycle and while the ABC LED indicator is on steady, as during the self-standardization cycle. This voltage should be +/-0.5 volt.</p>
<p>Mirror temperature cools below the actual dewpoint and large amounts of dew or frost build up on the mirror surface.</p>	<p>Press the MBAL key to put the instrument in the ABC mode and clean the mirror surface with isopropyl alcohol. Make sure no detergents are allowed on the mirror surface. If trouble persists, it may be caused by dirty optics. Clean the optics with isopropyl alcohol and a pipe cleaner. When the optics are clean the voltage drop across R51 should be greater than 5V.</p>

Test Points

The following test points are available on the main PC board:

TP1	The summing point of the main servo amplifier.
TP2	Output of servo amplifier. This voltage ultimately controls the Sensor current and is also the voltage represented by the CONTROL LEDs.
TP3	The Sensor current can be determined by measuring the voltage between TP3 and TPAGND (analogue ground) and dividing by 0.1.
TP4	TP3 and TP4 represent both sides of the Sensor
TP5	Represents the output of the PRT amplifier and is approximately 10V/100°C.
TP6	Output of D/A converter that generates the balance voltage.
TP7	The shifted balance voltage as presented to the summing point.
TP8 & 9	The differential inputs of the PRT amplifier.
TP10	The junction between the +15V and the phototransistors in the Sensor.
TP11	The junction between the -15V and the phototransistors in the Sensor.
TP12	The voltage generated by the thickness potentiometer (R64).
TPVCC	The +5V supply.
TPAGND	Analogue ground.
TPDGND	Digital ground.

WARRANTY STATEMENT

All equipment manufactured by Edgetech Instruments Inc. is warranted against defective components and workmanship for repair at their plant in Massachusetts, free of charge, for a period of twelve months. Malfunction due to improper use is not covered in this warranty and Edgetech Instruments Inc. disclaims any liability for consequential damage resulting from defects in the performance of the equipment. No product is warranted as being fit for a particular purpose and there is no warranty of merchantability. This warranty applies only if (i) the items are used solely under the operating conditions and in the manner recommended in the instruction manual, specifications, or other literature; (ii) the items have not been misused or abused in any manner or repairs attempted thereon; (iii) written notice of the failure within the warranty period is forwarded to Edgetech Instruments Inc. and the directions received for properly identifying items returned under warranty are followed; and (iv) the return notice authorizes Edgetech Instruments Inc. to examine and disassemble returned products to the extent Edgetech Instruments Inc. deems necessary to ascertain the cause for failure. The warranties expressed herein are exclusive. There are no other warranties, either expressed or implied, beyond those set forth herein, and Edgetech Instruments Inc. does not assume any other obligation or liability in connection with the sale or use of said products. Equipment not manufactured by Edgetech Instruments Inc. is supported only to the extent of the original manufacturer's warranties.

NOTES: