

Model 1500

Portable Dew Point Monitor

OPERATORS MANUAL



Rev B Sept 2017

TABLE OF CONTENTS

1.0 GENERAL DESCRIPTION

2.0 SAMPLE CONNECTIONS

2.1 SAMPLE CONNECTIONS

2.2 ALARM RELAY CONNECTIONS

2.3 OUTPUT CONNECTIONS

3.0 FUNCTIONAL DESCRIPTION

3.1 DISPLAY

3.2 MABC BUTTON

3.3 CLEAN MIRROR RELAY

3.4 FLOW CONTROL VALVE

3.5 ALARM RELAY OUTPUT

3.6 ANALOG OUTPUT

3.7 DISPLAY "SCAN" BUTTON

4.0 SETUP

4.1 ALARM SET POINTS

4.2 ABC INTERVAL

5.0 MAINTENANCE

5.1 ROUTINE MAINTENANCE

5.2 MIRROR CLEANING SCHEDULE

5.3 MIRROR CLEANING PROCEDURE

6.0 SPECIFICATIONS

7.0 APPENDICES

ROTARY VANE VACUUM PUMP (OPTIONAL)

PRESSURE TRANSDUCER (OPTIONAL)

EDGETECH INSTRUMENTS INC. DEW POINT HYGROMETER SAMPLING

BASIC HUMIDITY DEFINITIONS

BATTERY MATERIAL SAFETY DATA SHEET (FOR -C1 ONLY)

Edgetech Instruments Inc.'s Commitment to Quality

To Our Customers:

Thank you for purchasing one of our products. At Edgetech Instruments Inc., it is our policy to provide cost-effective products and support services that meet or exceed your requirements, to deliver them on time, and to continuously look for ways to improve both. We all take pride in the products we manufacture.

We want you to be entirely satisfied with your instrument. The information in this manual will get you started. It tells you what you need to get your equipment up and running, and introduces its many features.

We always enjoy hearing from the people who use our products. Your experience with our products is an invaluable source of information that we can use to continuously improve what we manufacture. We encourage you to contact or visit us to discuss any issues whatsoever that relate to our products or your application.

The Employees of Edgetech Instruments Inc.

1.0 GENERAL DESCRIPTION

The Edgetech Instruments Inc. Model 1500 Battery Powered DPM is an integrated system including a microprocessor-based instrument, a chilled mirror dew point sensor, a sample flow meter and associated tubing and fittings.

The Standard Instrument includes: (Other options available)

- An eight-digit, alphanumeric, LED display to report the dew point and system status.
- Periodic sensor balance check.
- Programmable Alarm Set Point with visual and contact closure alarm indications.
- Two SPDT (Form C) Alarm Relay.
- 4 - 20mA analog output.

FIGURE 1.1 CASE DIMENTIONS

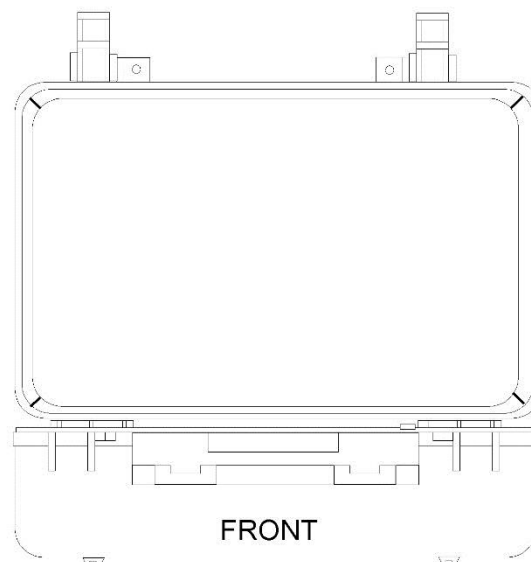
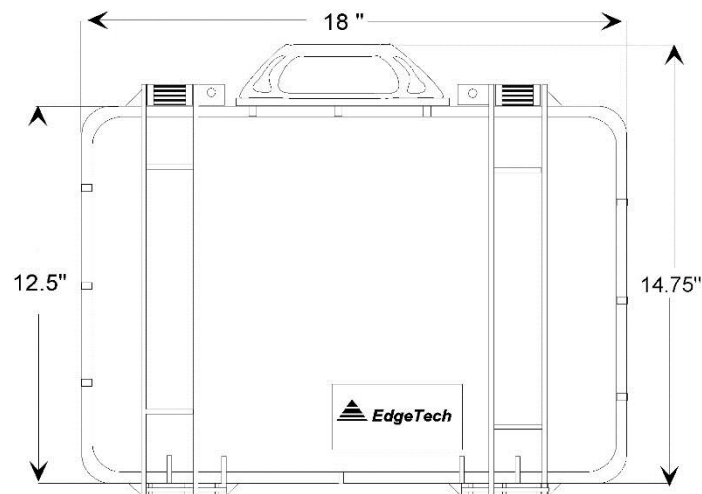

1500 Case Open

2.0 SAMPLE CONNECTIONS

2.1 SAMPLE CONNECTIONS

The sample may be brought to the instrument with ¼" copper, stainless steel, or plastic tubing and terminated in a ¼" female fitting.

Connect the sample supply line to the ¼" tubing fitting located on the panel (Figure 2.2).

NOTE: The maximum inlet pressure is 150 PSIG.

Figure 2-2.0 Drawing Model 1500-C1 & Model 1500-C2

Figure 2-2.1 Drawing Model 1500-C1-Sx "underneath"

Figure 2-2.2 Drawing Model 1500-C1-DsX "Insertion Probe"

2.4 ALARM RELAY CONNECTIONS

When the programmed Alarm Set Point conditions are met, the alarm relay will be energized. Before connecting any device to the Alarm Relay contacts, check the contact ratings in the Specifications section.

1. Connect one of the signal wires to the CA (Center Arm) and the other wire to either the NO (Normally Open) or NC (Normally Closed) terminal. Whichever is preferred by the installer. (See figure 2.3)

2.5 ANALOG OUTPUT CONNECTIONS

"4-20mA out". All connection can be made at terminal strip. (See figure 2.3)

1. Connect the high signal wire to the "+" terminal and the low side to the "-" terminal.

2.6 SERIAL PORT OUTPUT CONNECTIONS (Optional)

1. "RS232 out". (See figure 2.3)

FIGURE 2-2.0 TOP & BELOW PANEL LAYOUT
Model 1500-C1 "Battery Powered"
TOP

Model 1500-C2 "115/230VAC 50-60Hz"
TOP

FIGURE 2-2.1

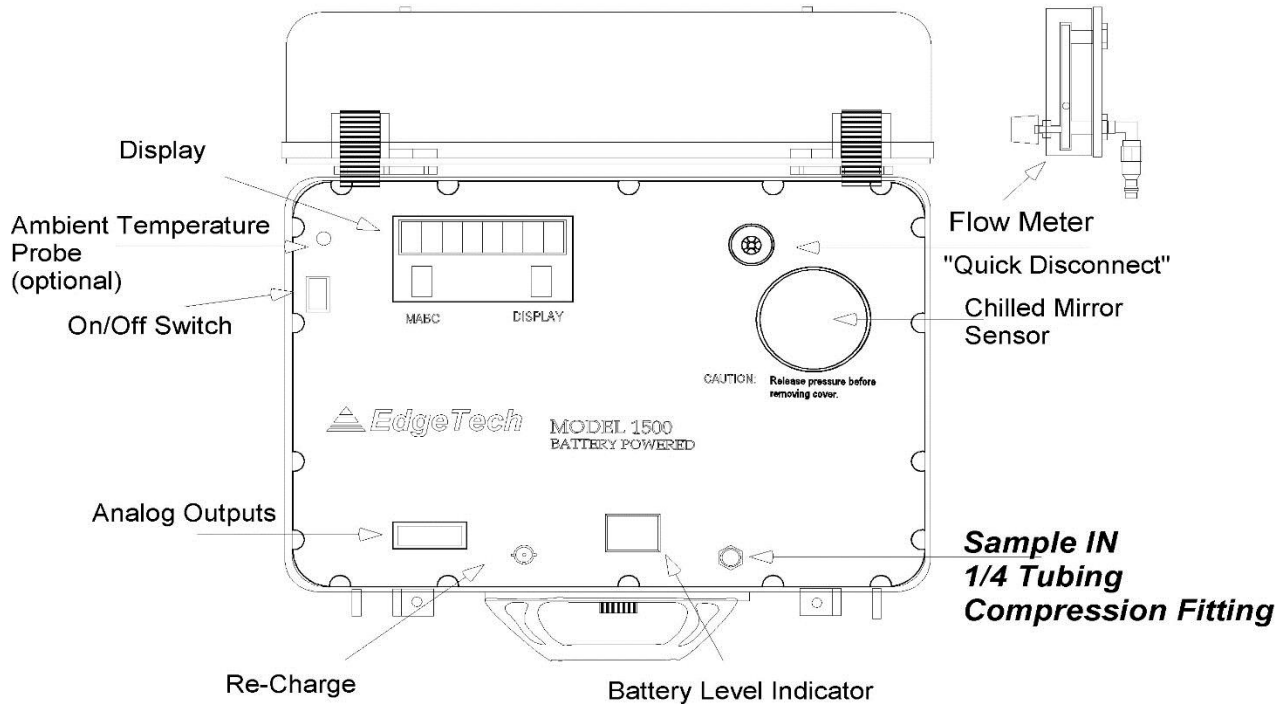
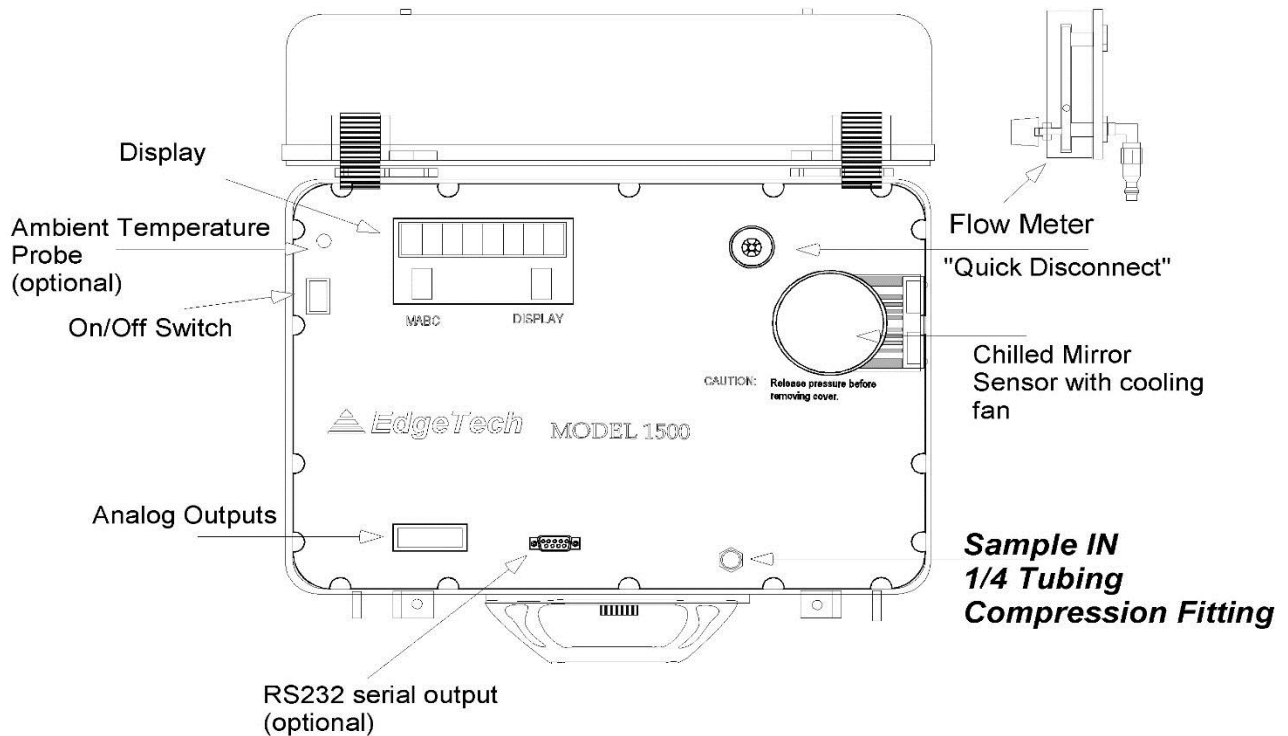
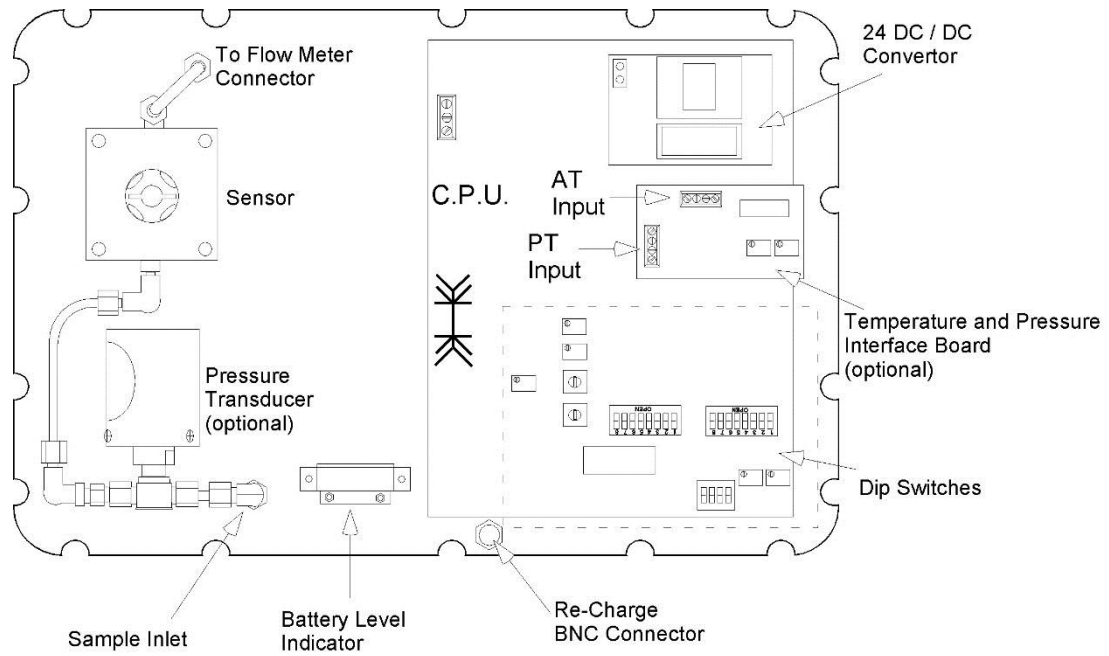

BELOW PANEL

FIGURE 2-2.2 Model 1500-C1-DSx

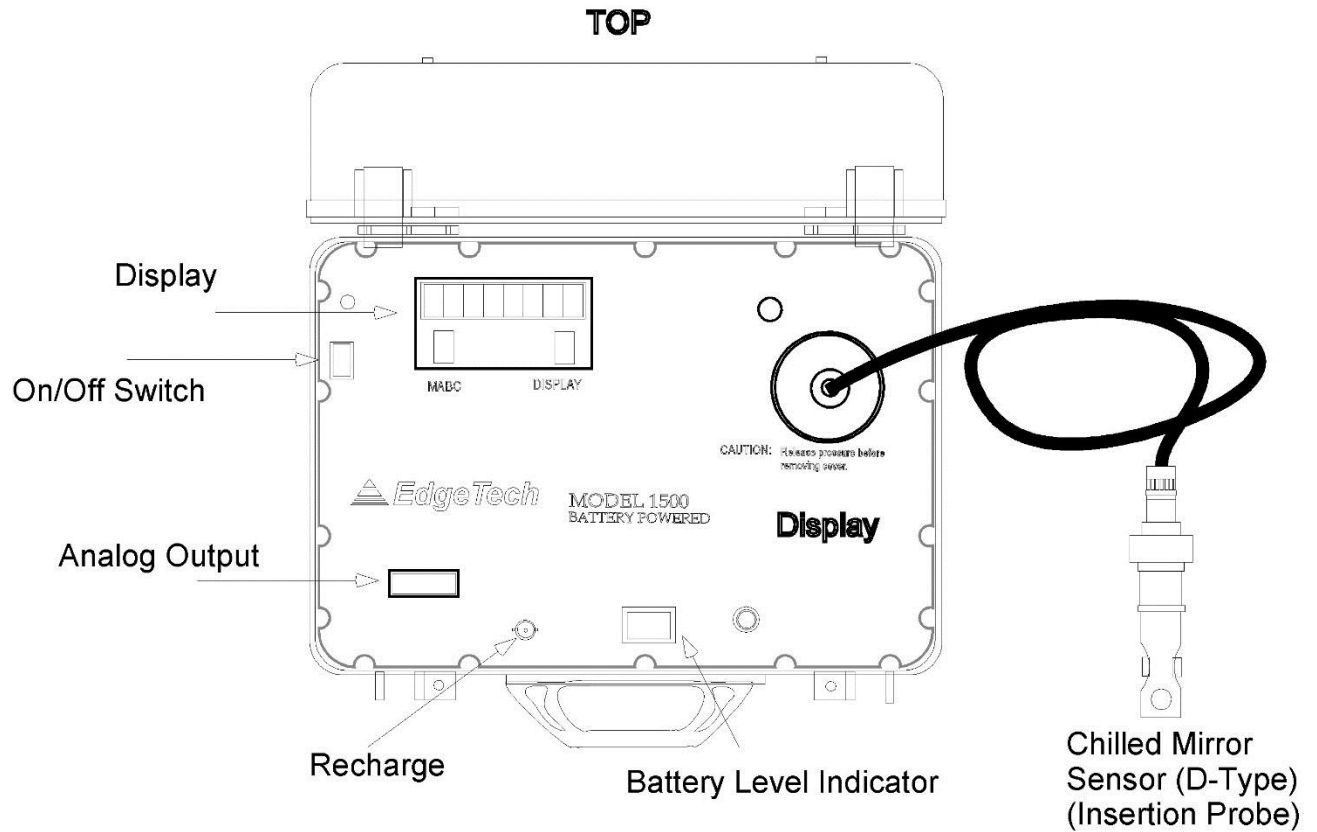
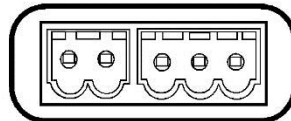
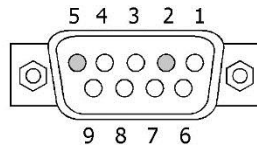
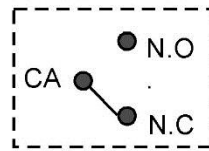

FIGURE 2-3 WIRING CONNECTORS
ANALOG OUTPUTS

(+) (-) CA NO NC
4-20mA ALARM RELAY



9-PIN Serial Port Connector
Use Pins # 2(+) & #5(-)

3.0 FUNCTIONAL DESCRIPTION

The front panel of the Model 1500 Battery Powered DPM consists of an LED Display and two push-buttons.

1.) **MABC**- Manual Automatic Balance Cycle

2.) **DISPLAY “SCAN”**- Allows viewing of all Parameters or selection of desired measurement.

3.1 Display

The eight character alphanumeric LED display is used to display dew point data and status messages.

Dew point data is displayed as “DP 34.8 F”, with the units in degrees C or F. (See Set-Up section)

When a status message is necessary, the display will alternate between the data and the message at about 2 second intervals.

The possible status messages and their meanings are:

- **“ABC CYCL”** : Indicates that an Automatic Balance Cycle is in progress.
During an ABC Cycle;
The mirror is heated above the ambient temperature for a period of 1 to 3 minutes as determined by the last measured dew point.
After sufficient time has elapsed to ensure that the mirror is dry, the reflected light level of the mirror is measured and if necessary, adjusted to the reference level.
After the adjustment is made, the instrument will begin cooling and seeking the dew point. When a stable lock on the dew point is achieved, the “ABC CYCL” message will disappear, and normal operation will resume.
The analog output is held to the dew point value just before the cycle started until the completion of the ABC cycle.
If an alarm condition is present when the ABC cycle begins, the audible alarm and the ALARM display are disabled but the Alarm Relay remains energized.
- **“ALARM”**: The Alarm Set Point has been exceeded. The Alarm Relay will be energized.
- **“CLN MIRR”**: During an ABC Cycle, the condition of the sensor mirror and optics are analyzed and a correction is made for changes in the reflectivity since the last cycle. If the mirror reflectivity has *decreased* beyond the automatic correction range, this message will appear at the end of the ABC cycle and indicates that the sensor mirror needs a manual cleaning. Perform the “Mirror Cleaning Procedure” in the MAINTENANCE and CALIBRATION Section.

Note: The instrument may *appear* to operate normally with this message present, but the data should not be relied upon, until the appropriate maintenance is performed.

3.0 FUNCTIONAL DESCRIPTION (CONTINUED)

- “**CHK SNSR**” : If during the ABC Cycle, the reflectivity has *increased* significantly due to excessive drift of the optics, or abnormal circuit performance, this message will appear. To determine the cause, take the following steps.
 - Clean the mirror.
 - Initiate an MABC Cycle.
 - Check the sample system for proper flow.
 - Check for loose connections or components on the printed circuit board and sensor.

If the condition cannot be resolved with these checks, contact Edgetech Instruments Inc. for service.

3.2 MABC Button

Pressing the MABC Button (**M**anual **A**utomatic **B**alance **C**ycle) at any time will initiate an ABC Cycle.

3.3 Clean Mirror Relay Output

The Clean Mirror Relay is a SPDT relay that is energized whenever maintenance to the mirror is required.

During an ABC cycle, all alarm functions, including the relay, are disabled.

However, if an ABC Cycle is initiated when an alarm condition is present, the relay will remain energized until the cycle is complete.

At the end of the cycle the relay will remain energized if the clean mirror condition is still present or be de-energized if the alarm condition has passed.

3.4 Flow Control Valve

The sample flow rate is adjusted using this valve. Although the sample flow rate is not critical for proper operation, the recommended rate is 1 – 2 SCFH (**S**tandard **C**ubic **F**eet per **H**our).

3.5 Alarm Relay Output

The Alarm Relay is a SPDT relay that is energized whenever the dew point exceeds the Alarm Set Point.

During an ABC cycle, all alarm functions, including the relay, are disabled.

However, if an ABC Cycle is initiated when an alarm condition is present, the relay will remain energized until the cycle is complete.

At the end of the cycle the relay will remain energized if the alarm condition is still present or be de-energized if the alarm condition has passed.

3.6 Analog Output

The analog output is a 4 to 20 ma output, proportional to the dew point, and scaled at the factory for –58 to 122 °F (-50 to 50 °C).

During an ABC Cycle, the output is “held” at the dew point until the cycle is completed.

3.7 Display “SCAN” Button

Display feature allows the viewing of select parameter or scanning of all three parameters at 3-second intervals.

4.0 SETUP

4.1 Alarm Set Point (Figure 4.1)

The alarm set point temperature is set by DIP switch S2 as an integer. The switch setting represents an eight bit binary number in degrees C with position 8 as the least significant bit (LSB) and position 2 as the most significant bit (MSB). Position 1 is the sign bit.

An 'open' switch is a '1' and 'closed' is a '0'.

If the desired set point is in degrees F, convert it to Celsius before proceeding.

Set the switches as follows:

1. Convert the desired set point temperature from degrees C to its eight bit binary equivalent code. Table 4.1 is provided to convert F to C and the equivalent eight bit binary code.
2. Set S1-1 'closed' and S1-2 'open'. The alarm temperature setting will be displayed in degrees C.

NOTE: S1-1 determines whether C or F is displayed in both the measurement and alarm set modes.

S1-2 will switch the display between the dew point and the Alarm Setting.

3. Set S2, positions 1 through 8 according to the eight bit binary number determined in step 1. A '1' is 'open', and a '0' is 'closed'.
4. The display should now read the set point temperature in degrees Celsius.
5. If Fahrenheit units are desired, set S1-1 to 'open'.
6. Return to dew point display by setting S1-2 'closed'.

FIGURE 4-1 SETUP

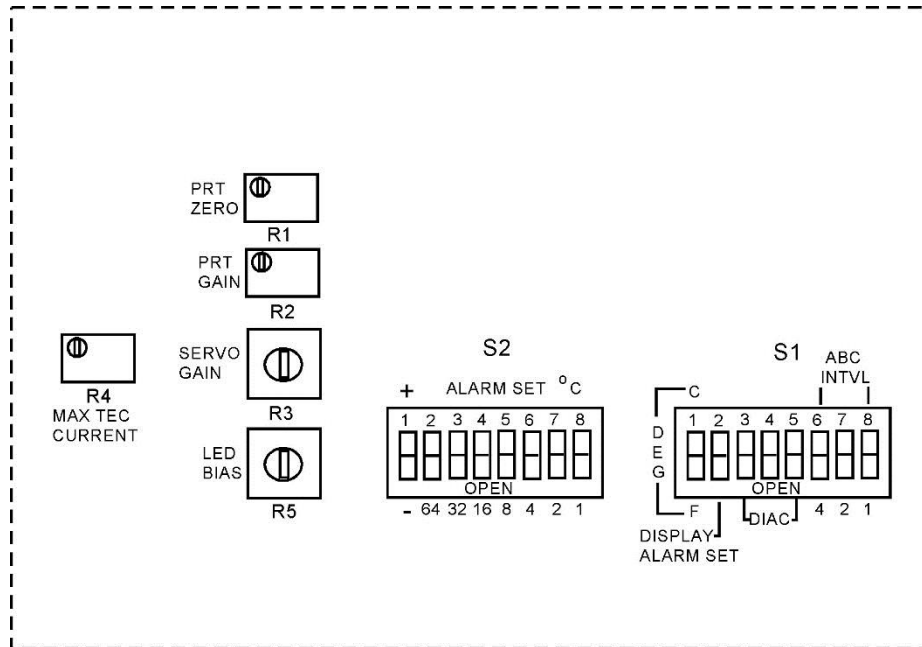

TABLE 4.1 SETUP

C	F	BINARY	C	F	BINARY
-50.0	-58.0	10110010	0.0	32.0	00000000
-49.0	-56.0	10110001	1.0	33.0	00000001
-48.0	-54.0	10110000	2.0	35.0	00000010
-47.0	-52.0	10101111	3.0	37.0	00000011
-46.0	-50.0	10101110	4.0	39.0	00000100
-45.0	-49.0	10101101	5.0	41.0	00000101
-44.0	-47.0	10101100	6.0	42.0	00000110
-43.0	-45.0	10101011	7.0	44.0	00000111
-42.0	-43.0	10101010	8.0	46.0	00001000
-41.0	-41.0	10101001	9.0	48.0	00001001
-40.0	-40.0	10101000	10.0	50.0	00001010
-39.0	-38.0	10100111	11.0	51.0	00001011
-38.0	-36.0	10100110	12.0	53.0	00001100
-37.0	-34.0	10100101	13.0	55.0	00001101
-36.0	-32.0	10100100	14.0	57.0	00001110
-35.0	-31.0	10100011	15.0	59.0	00001111
-34.0	-29.0	10100010	16.0	60.0	00010000
-33.0	-27.0	10100001	17.0	62.0	00010001
-32.0	-25.0	10100000	18.0	64.0	00010010
-31.0	-23.0	10011111	19.0	66.0	00010011
-30.0	-22.0	10011110	20.0	68.0	00010100
-29.0	-20.0	10011101	21.0	69.0	00010101
-28.0	-18.0	10011100	22.0	71.0	00010110
-27.0	-16.0	10011011	23.0	73.0	00010111
-26.0	-14.0	10011010	24.0	75.0	00011000
-25.0	-13.0	10011001	25.0	77.0	00011001
-24.0	-11.0	10011000	26.0	78.0	00011010
-23.0	-9.0	10010111	27.0	80.0	00011011
-22.0	-7.0	10010110	28.0	82.0	00011100
-21.0	-5.0	10010101	29.0	84.0	00011101
-20.0	-4.0	10010100	30.0	86.0	00011110
-19.0	-2.0	10010011	31.0	87.0	00011111
-18.0	0.0	10010010	32.0	89.0	00100000
-17.0	1.0	10010001	33.0	91.0	00100001
-16.0	3.0	10010000	34.0	93.0	00100010
-15.0	5.0	10001111	35.0	95.0	00100011
-14.0	6.0	10001110	36.0	96.0	00100100
-13.0	8.0	10001101	37.0	98.0	00100101
-12.0	10.0	10001100	38.0	100.0	00100110
-11.0	12.0	10001011	39.0	102.0	00100111
-10.0	14.0	10001010	40.0	104.0	00101000
-9.0	15.0	10001001	41.0	105.0	00101001
-8.0	17.0	10001000	42.0	107.0	00101010
-7.0	19.0	10000111	43.0	109.0	00101011
-6.0	21.0	10000110	44.0	111.0	00101100
-5.0	23.0	10000101	45.0	113.0	00101101
-4.0	24.0	10000100	46.0	114.0	00101110
-3.0	26.0	10000011	47.0	116.0	00101111
-2.0	28.0	10000010	48.0	118.0	00110000
-1.0	30.0	10000001	49.0	120.0	00110001
0.0	32.0	00000000	50.0	122.0	00110010

4.2 ABC Interval

The ABC Interval is the time between the automatic initiation of ABC Cycles. In typical applications, an interval of 24 hours is recommended and set at the factory. However, in cases where ambient conditions are more variable, or the sample gas is higher in contaminants, a shorter interval may be required.

The times listed below are approximate.

The interval is adjustable in 4 hour increments from 4 to 28 hours.

Switch positions S1-6, -7, and -8 represent a three bit binary code with a weight of 4 hrs. per unit.

To set the interval, set S1-6, S1-7, and S1-8 according to the binary number from Table 4.2 below. The factory default is 24 hrs.

NOTE: 'CLOSED' is a zero and 'OPEN' is a one.

ABC INTERVAL	S1- 6	S1- 7	S1- 8
OFF	0	0	0
4 hrs.	0	0	1
8 hrs.	0	1	0
12 hrs.	0	1	1
16 hrs.	1	0	0
20 hrs.	1	0	1
24 hrs.	1	1	0
28 hrs.	1	1	1

Table 4.2 converts the required interval in hours to a three bit binary number.

5.0 MAINTENANCE

5.1 ROUTINE MAINTENANCE

To ensure the maximum in accurate and reliable operation of any optical chilled mirror system, a periodic maintenance program should be established.

5.2 MIRROR CLEANING SCHEDULE

Over time, particulates and other matter present in the sample gas and not captured by filters, build up on the mirror. The result of the buildup of contaminants on the mirror surface is reduced dry mirror reflectivity and a change in the optical reference point. The ABC Cycle will automatically readjust the optics to the reference point periodically, but eventually the adjustment range will be exceeded and a manual cleaning of the mirror may be necessary. When the contamination becomes too much to be adjusted automatically, an error will be displayed at the end of the ABC Cycle.

Normally, intervals of 90 days between routine mirror cleanings can be easily achieved.

However, if the sample gas contaminants are particularly high, more frequent mirror cleanings may be required.

5.3 MIRROR CLEANING PROCEDURE (Figure 5.1)

When mirror cleaning is required as a periodic maintenance item or the “CLN MIRR” or “CHK SNSR” message appears on the display, proceed as follows.

1. Turn power off.

CAUTION!

When operating with a pressurized sampling system, be sure to remove pressure from the Sensor prior to removing the Sensor cover.

2. Remove the spin-off cover from the Sensor to expose the mirror.
3. Moisten a clean cotton swab with isopropyl alcohol. Cotton swabs and cleaner are provided in the Cleaning Kit supplied with the system.
4. Wipe the mirror surface and the optics surface in a circular motion.
5. After cleaning the mirror surface, wipe the surfaces dry with a clean Q-tip.
6. Next, moisten a clean Q-tip with clean, preferably distilled water and wipe the mirror and optics areas.
7. Dry these areas thoroughly with a clean, dry Q-tip.
8. Replace the sensor cover.
9. Re-establish sample pressure and flow.
10. Turn power on.

FIGURE 5.1 S1/S2 WITH COVER REMOVED FOR MIRROR CLEANING

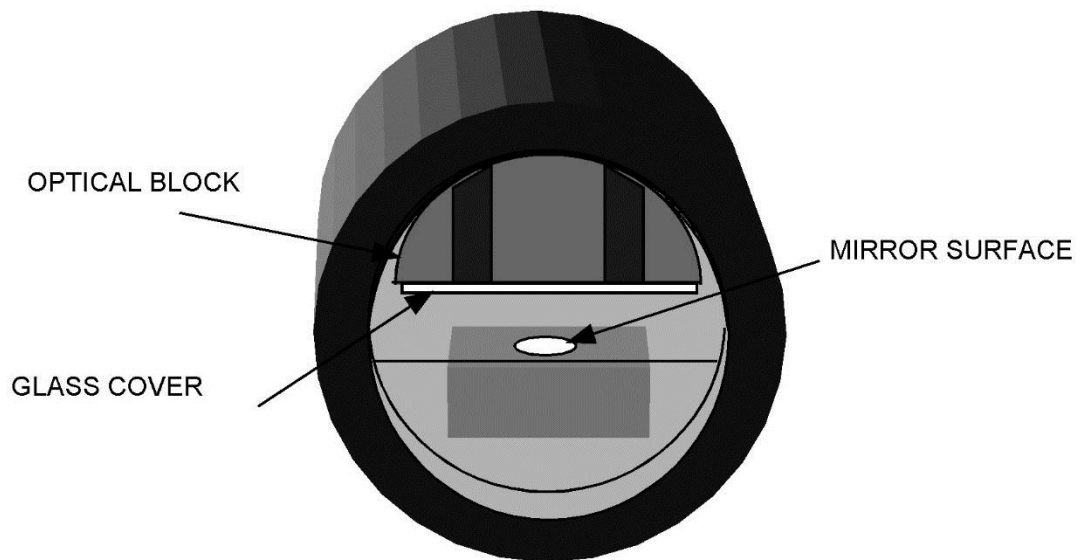
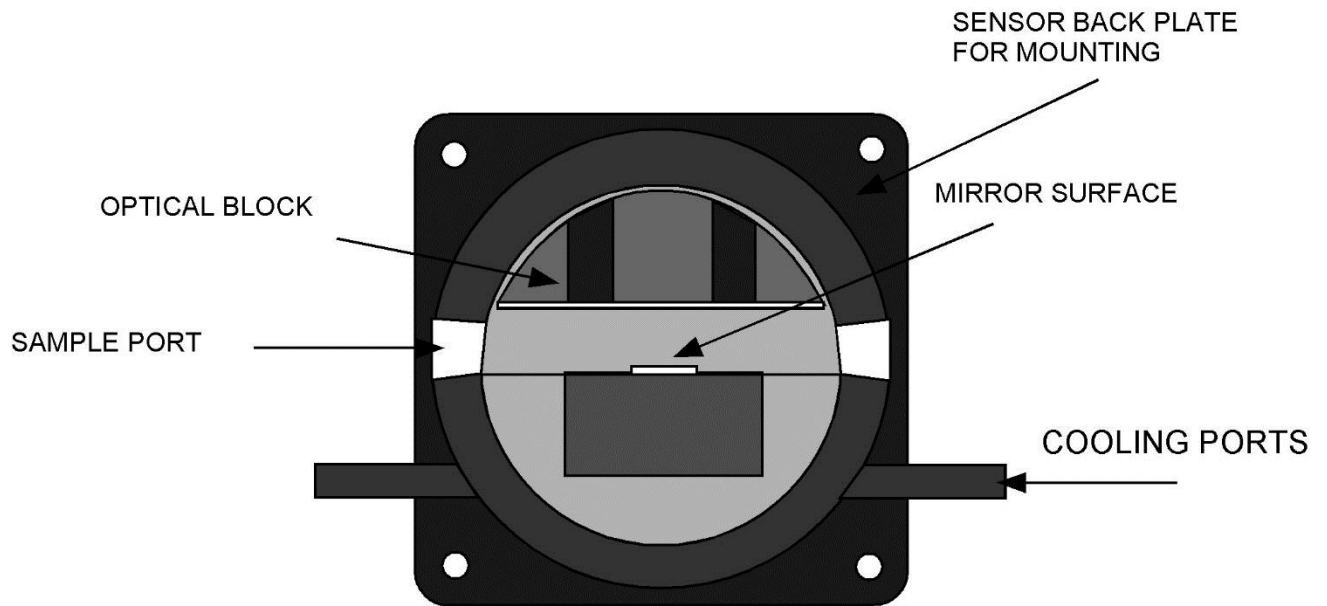

**Front View
"Cover Removed"
S1/S2 Sensor**

6.0 SPECIFICATIONS

Measurement Range

-Dew/ Frost Point	-20 to 50°C (Standard S1 Sensor) -50 to 50°C (Optional S2 sensor)** -75 to 75°C (Optional S3 sensor)**
-Pressure Transducer	0-150 p.s.i.g. (gauge)
-Ambient Temperature Probe	-50°C to 50°C -58°F to 122°F

Measurement Accuracy

-Dew/ Frost Point	±0.25°C (0.45°F) Entire Range
-Pressure Transducer	±0.5% (Full Scale)
-Ambient Temperature Probe	±0.2°C (0.36°F) Entire Range

Functional

Power/ Charger:	115VAC/60Hz, or 230VAC/50Hz; 40 watts(Max)
Operating Temperature:	
Control Unit/Sensor	
S-Type	32 to 122°F (0 to 50°C)
D-Type	32 to 185°F (0 to 85°C)
Sample Connection:	¼ female compression tubing fitting
Sample Flow:	0.5 to 5scfh, Integral flow meter
Sample Pressure:	0 to 150psig max
Analog Output:	4 to 20mA, <i>Scaled</i>
Range:	Selectable(See available sensor ranges)
Compliance:	9.0 VDC, 450 ohms
Display:	Eight Digit Alphanumeric LED, 0.5" High.
High dew point Alarm:	
- Visual	Flashing Message on Display
- Relay Contacts	2 Form C, non-latching, 10A @ 240VAC 8A @ 24 VDC ½ HP @ 240VAC

Physical

Dimensions:	14.75"H x 18"L x 7"W
Weight:	C1(24 lbs.) C2 (14 lbs.)

Standard Features

- Microprocessor Controlled.
- 8 Digit Alphanumeric LED Display.
- Automatic Balance Control.(ABC)
- User settable high alarm limit.
- Alarm Relay, Form C.
- Analog Output, 4 – 20 ma.
- Integral flow meter.
- Visual alarms
- Battery Level Indicator & Charger

Optional Features

- Pressure transducer; required for PPMv
- Rotary Vane Vacuum Pump
- Ambient Temperature; required for %RH
- RS232 Serial Port
- Probe Style Sensor

7.0 APPENDIX

Rotary Vane Vacuum Pump Specifications



Pressure/Vacuum Pump Models DC Powered Rotary Vane Pumps DESCRIPTION

These rotary vane pumps are an excellent pressure/vacuum source for gas analyzers, medical devices, process samplers and other analytical instrument applications. They are also useful for material handling and many general automation applications.

The pumps are quiet, reliable and mount in any position.

The units operate oil free. The pump vanes have a service life of 10,000 hours and are easily field replaced without special tools

SPECIFICATIONS

Maximum Differential pressure- 180 mbar

Maximum Flow- 2.9 LPM

Vane Material- Carbon

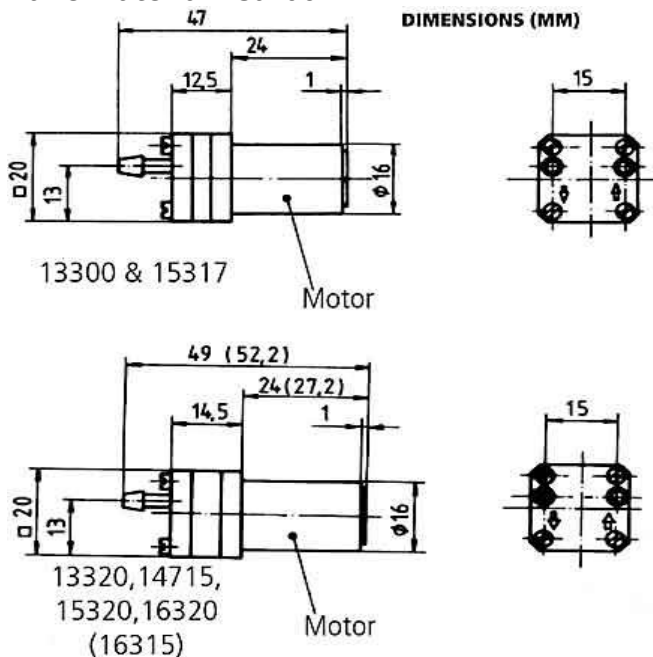

Note:

Operation at a somewhat lower than pump design voltage will yield a significantly longer life of the motor and the pump while also decreasing the current draw and operating noise of the unit.

If used for continuous operation, please note that the electrical current should be at least 10% below the specified design current draw. Consequently, we recommend that you select a pump that has a slightly higher pumping capacity than needed during normal operation.

Model Number	Voltage	Max. Flow L/min	Max. Pressure mbar	Min. Current mA	Max. Current mA	weight-grams
13300	6	1.5	120	150	230	38
15317	12	1.9	160	140	200	38
13320	6	2.2	120	180	290	41
14715	9	2.5	150	180	280	41
15320	12	2.6	160	180	270	41
16320	24	2.9	180	130	180	41
16315	24	2.2	80	80	100	47

Model 205-2

Specifications	
Full Scale Pressure Output	5 VDC
Zero Pressure Output	0 VDC
Accuracy (RSS Method)	±0.11% Full Scale (0.073% Full Scale, optional)
Type of Pressure	Gage or Absolute
Pressure Ranges	0 to 25, 50, 100, 250 psig 0 to 25, 50, 100, 250 psia
Thermal Effects	Compensated Range °F (°C): 30 to 160 (-1 to 65) %FS/100°F(100°C)max.zero: ±2.0 (±3.6) %FS/100°F(100°C)max.span: ±1.5 (±2.7)
Media	Gases compatible with 17-4PH stainless steel. (Hydrogen not recommended for use with 17-4PH stainless steel.)

Declaration of Compliance for UN2800

Subject: UN2800, class 8, Batteries Wet, None Spillable, Electric Storage

Edgetech Instruments Inc. hereby certify that the Eagle Picher “Care free” rechargeable lead acid battery, CR-12V4.5AH (20hr) used on the Edgetech Instruments 1500DC portable chilled mirror hygrometer. Manufactured by Edgetech Instruments in the USA.

Transport Information: Batteries: UN2800, Wet, Non-Spillable, Electric Storage. Class 8. DOT: Excepted from regulations, meets the requirements of 49 CFR 173.159 IATA/ICAO: Not Restricted, meets the requirements of Special Provision A48, A67, A164, 183, PI 872 (IATA 58th Edition) IMDG: Excepted from regulations, meets the requirements in Special Provision 238.

Carefree Batteries having met the related conditions are exempt from hazardous good regulations for the purpose of transportation by DOT, IATA/ICAO, and IMDG, therefore are unrestricted for all modes of transportation. Each battery and outer package is labeled “Non-Spillable” or “Non-Spillable Battery” and packaged as to prevent short circuit